

Provided by:
Cinder & Concrete Block Corporation

National Concrete Masonry Association
an information series from the national authority on concrete masonry technology

NCMA TEK

FIRE RESISTANCE RATING OF CONCRETE MASONRY ASSEMBLIES

TEK 7-1A
Fire Resistance (2003)

Keywords: calculated fire resistance rating, columns, control joints, equivalent thickness, fire resistance ratings, fire walls, multi-wythe walls, specifications

INTRODUCTION

This TEK conforms to the stated parameters of the *Standard Method for Determining Fire Resistance of Concrete and Masonry Construction Assemblies*, ACI 216.1-97/TMS 0216.1-97 (ref. 1—hereinafter referred to as the Standard). Concrete masonry is widely specified for fire walls and fire separation walls because these elements are:

- noncombustible,
- provide durable fire resistance, and
- are economical to construct.

For the most part, the contents of the Standard are not new, but rather are a compilation and refinement of the many documents previously published by the various segments of the masonry and concrete industry. More importantly, the Standard is a document that has gone through a formal consensus process and is written in mandatory language, and therefore is now incorporated by reference into the national model codes.

Methods of Determining Fire Resistance Ratings

The fire resistance rating period of concrete masonry elements can be determined by three methods:

- calculation,
- through a listing service, or
- by testing.

The calculation method is the most practical and most commonly used method of determining the fire resistance rating of concrete masonry. It is based on extensive research which established a relationship between physical properties of materials and the fire resistance rating. The calculation method is utilized in the Standard which determines fire resistance ratings based on the equivalent thickness of concrete masonry units and aggregate types used in their manufacture.

An alternative to the calculation method is provided by private commercial listing services. The listing service approach allows the designer to select a fire rated assembly which has been previously classified and listed in a published

directory of listed fire rated assemblies. The listing service also monitors materials and production to verify that the concrete masonry units are and remain in compliance with appropriate standards. A premium is usually charged for units of this type. The system also is somewhat inflexible in that little variation from the original tested wall assembly is allowed including unit size, shape, mix design, ingredients, and even the plant of manufacture.

The third option, testing of representative elements of the construction in accordance with standard fire test methods is generally not practical due to the expense of the test and time required to build, cure, and test representative specimens.

CALCULATED FIRE RESISTANCE METHOD

Scope

This TEK covers methods for determining the fire resistance rating of concrete masonry assemblies, including walls, columns, lintels, beams, and concrete masonry fire protection for steel columns. It also includes assemblies composed of concrete masonry and other components including plaster and drywall finishes, and multi-wythe masonry components including clay or shale masonry units.

Background

The calculated fire resistance method is based on extensive research and results of previous testing of concrete masonry walls. Fire testing of wall assemblies is conducted in accordance with the *Standard Test Methods for Fire Tests of Building Construction and Materials*, ASTM E 119 (ref. 7) which measures four performance criteria.

ASTM E 119 Performance Criteria:

- resistance to the transmission of heat through the wall assembly,
- resistance to the passage of hot gases through the wall sufficient to ignite cotton waste,
- load carrying capacity of loadbearing walls, and
- resistance to the impact, erosion, and cooling effects of a hose stream on the assembly after exposure to the standard fire.

The fire resistance rating of concrete masonry is typically governed by the heat transmission criteria. This type of failure mode is certainly preferable to a structural collapse endpoint characteristic of many other building materials from the standpoint of life safety (particularly for fire fighters)

Table 1—Fire Resistance Rating Period of Concrete Masonry Assemblies (ref. 1)

Aggregate type in the concrete masonry unit ²	Minimum required equivalent thickness for fire resistance rating, in. (mm) ¹						
	4 hours	3 hours	2 hours	1.5 hours	1 hour	0.75 hours	0.5 hours
Calcareous or siliceous gravel	6.2 (157)	5.3 (135)	4.2 (107)	3.6 (91)	2.8 (71)	2.4 (61)	2.0 (51)
Limestone, cinders or slag	5.9 (150)	5.0 (127)	4.0 (102)	3.4 (86)	2.7 (69)	2.3 (58)	1.9 (48)
Expanded clay, shale or slate	5.1 (130)	4.4 (112)	3.6 (91)	3.3 (84)	2.6 (66)	2.2 (56)	1.8 (46)
Expanded slag or pumice	4.7 (119)	4.0 (102)	3.2 (81)	2.7 (69)	2.1 (53)	1.9 (48)	1.5 (38)

1. Fire resistance rating between the hourly fire resistance rating periods listed may be determined by linear interpolation based on the equivalent thickness value of the concrete masonry assembly.
2. Minimum required equivalent thickness corresponding to the hourly fire resistance rating for units made with a combination of aggregates shall be determined by linear interpolation based on the percent by volume of each aggregate used in the manufacture.

and salvageability.

Fire testing of concrete masonry columns evaluates the ability of the column to carry design loads under standard fire test conditions. Fire testing of a concrete masonry protected steel column assembly evaluates the structural integrity of the steel column under fire test conditions by measuring the temperature rise of the steel.

Fire testing of concrete masonry beams and lintels evaluates the ability of the member to sustain design loads under standard fire test conditions. This is accomplished by insuring that the temperature rise of the tensile reinforcing does not exceed 1100 °F (593 °C) during the rating period.

Equivalent Thickness

Extensive testing has established a relationship between the fire resistance and the equivalent solid thickness for concrete masonry walls as shown in Table 1. Equivalent thickness is essentially the solid thickness that would be obtained if the same amount of masonry contained in a hollow unit were recast without core holes. The equivalent thickness of a hollow unit is equal to the percentage solid times the actual thickness of the unit. See Figure 1. The percentage solid is determined in accordance with *Standard Methods of Sampling and Testing Concrete Masonry Units*, ASTM C 140 (ref. 2).

The equivalent thickness of a 100% solid unit or a solid grouted unit is equal to the actual thickness. For partially grouted walls where the unfilled cells are left empty, the equivalent thickness for fire resistance rating purposes is

equal to that of an ungrouted unit.

Loadbearing units conforming to ASTM C 90 (ref. 6) that are commonly available include 100% solid units, 75% solid units, and hollow units meeting minimum required face shell and web dimensions. Typical equivalent thickness values for these units are listed in Table 2.

Filling Cells with Loose Fill Material

If the cells of hollow unit masonry are filled with approved materials, the equivalent thickness of the assembly can be considered the same as the actual thickness. The list of approved materials includes: sand, pea gravel, crushed stone, or slag that meets ASTM C 33 (ref. 3) requirements; pumice, scoria, expanded shale, expanded clay, expanded slate, expanded slag, expanded flyash, or cinders that comply with ASTM C 331 (ref. 4) or C 332 (ref. 5), or perlite or vermiculite meeting the requirements of ASTM C 549 and C 516 (refs. 9 and 8), respectively.

Wall Assemblies

The fire resistance rating is determined in accordance with Table 1 utilizing the appropriate aggregate type of the masonry unit and the equivalent thickness. Units manufactured with a combination of aggregate types are addressed by footnote (2) which may be expressed by the following equation:

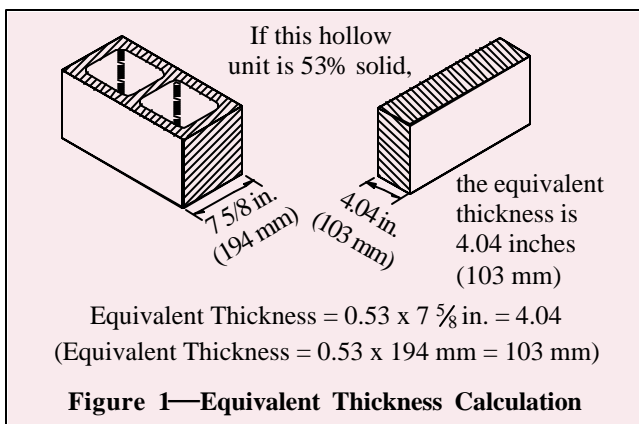

Table 2—Equivalent Thickness of Concrete Masonry Units, in. (mm)

Nominal width, in. (mm)	Based on typical hollow units ¹	Based on percent solid	
		(75%)	(100%)
4 (102)	2.7 (69) [73.8]	2.7 (69)	3.6 (91)
6 (152)	3.1 (79) [55.0]	4.2 (107)	5.6 (142)
8 (203)	4.0(102) [53.0]	5.7 (145)	7.6 (193)
10 (254)	5.0(127) [51.7]	7.2 (183)	9.6 (244)
12 (305)	5.7(145) [48.7]	8.7 (221)	11.6 (295)

1. Values in brackets [] are percent solid values based on typical two core concrete masonry units.

$$T_r = (T_1 \times V_1) + (T_2 \times V_2)$$

Where:

- T_r = required equivalent thickness for a specific fire resistance rating of an assembly constructed of units with combined aggregates, in. (mm)
- T_1, T_2 = required equivalent thickness for a specific fire resistance rating of a wall constructed of units with aggregate types 1 and 2, respectively, in. (mm)
- V_1, V_2 = fractional volume of aggregate types 1 and 2, respectively, used in the manufacture of the unit

Blended aggregate example:

The required equivalent thickness of an assembly constructed of units made with expanded shale (80% by volume), and calcareous sand (20% by volume), to meet a 3 hour fire resistance rating is:

$$T_1 \text{ for expanded shale (3 hour rating)} = 4.4 \text{ in. (112 mm)}$$

$$T_2 \text{ for calcareous sand (3 hour rating)} = 5.3 \text{ in. (135 mm)}$$

$$T_r = (4.4 \times 0.80) + (5.3 \times 0.20) = 4.58 \text{ in. (116 mm)}$$

Multi-Wythe Wall Assemblies

The fire resistance rating of multi-wythe walls (Figure 2) is based on the fire resistance of each wythe and the air space between each wythe in accordance with the following Equation.

$$R = (R_1^{0.59} + R_2^{0.59} + \dots + R_n^{0.59} + A_1 + A_2 + \dots + A_n)^{1.7}$$

Where:

- R_1, R_2, \dots, R_n = fire resistance rating of wythe 1, 2, ..., n, respectively (hours).
- A_1, A_2, \dots, A_n = 0.30; factor for each air space, 1, 2, ..., n, respectively, having a width of 1/2 to 3 1/2 in. (13 to 89 mm) between wythes. Note: It does not matter which side is exposed to the fire.

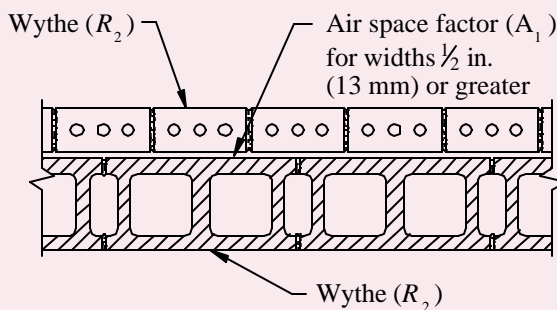

- R_1 = Fire resistance rating of wythe 1
- R_2 = Fire resistance rating of wythe 2
- A_1 = Air space factor = 0.3

Figure 2—Fire Resistance of Multi-Wythe Masonry Wall (ref. 1)

For multi-wythe walls of clay brick and concrete masonry, use the values of Table 3 for the brick wythe in the above equation.

Table 3—Fire Resistance of Brick or Tile of Clay or Shale (ref.1)				
Material type	Minimum required equivalent thickness ¹ for fire resistance rating, in. (mm)			
	4 hours	3 hours	2 hours	1 hour
≥ 75% solid	6.0 (152)	4.9 (124)	3.8 (97)	2.7 (69)
Hollow units ²	5.0 (127)	4.3 (109)	3.4 (86)	2.3 (58)
Hollow units ³	6.6 (168)	5.5 (140)	4.4 (112)	3.0 (76)

1. See section entitled "Equivalent Thickness" for calculation.
 2. Unfilled hollow units.
 3. Grouted or filled per section entitled "Filling Cells with Loose Fill Material".

Reinforced Concrete Masonry Columns

The fire resistance rating of reinforced concrete masonry columns is based on the least plan dimension of the column as indicated in Table 4. The minimum required cover over the vertical reinforcement is 2 in. (51 mm).

Table 4—Reinforced Concrete Masonry Columns (ref. 1)			
Minimum column dimensions, in. (mm), for fire resistance rating of:			
1 hour	2 hours	3 hours	4 hours
8 (203)	10 (254)	12 (305)	14 (356)

Concrete Masonry Lintels

The fire resistance rating of concrete masonry lintels is determined based upon the nominal thickness of the lintel and the minimum cover of longitudinal reinforcement in accordance with Table 5. Cover requirements in excess of 1 1/2 in. (38 mm) protect the reinforcement from strength degradation due to excessive temperature during the fire exposure period. Cover requirements may be provided by masonry units, grout, or mortar.

Table 5—Reinforced Concrete Masonry Lintels Minimum Longitudinal Reinforcing Cover, in. (mm) (ref. 1)				
Nominal lintel width, in., (mm)	Fire resistance rating			
	1 hour	2 hours	3 hours	4 hours
6 (152)	1 1/2 (38)	2 (51)	-	-
8 (203)	1 1/2 (38)	1 1/2 (38)	1 3/4 (44)	3 (76)
10 (254) or more	1 1/2 (38)	1 1/2 (38)	1 1/2 (38)	1 3/4 (44)

Control Joints

Figure 3 shows control joint details in fire rated wall assemblies in which openings are not permitted or where openings are required to be protected. Maximum joint width is 1/2 in. (13 mm).

Steel Columns Protected by Concrete Masonry

The fire resistance rating of steel columns protected by concrete masonry as illustrated in Figure 4 is determined by the following equation:

$$R = 0.401(A_{st}/p_s)^{0.7} + \{0.285(T_{ea}^{1.6}/k^{0.2}) \times [1.0 + (42.7\{(A_{st}/DT_{ea})/(0.25p + T_{ea})\}^{0.8})]\} \text{ (English units)}$$

$$R = 7.13(A_{st}/p_s)^{0.7} + \{0.0027(T_{ea}^{1.6}/k^{0.2}) \times [1.0 + (2.49 \times 10^7 \{(A_{st}/DT_{ea})/(0.25p + T_{ea})\}^{0.8})]\} \text{ (SI units)}$$

Where:

- R = Fire resistance rating of the column assembly, hr.
- A_{st} = Cross-sectional area of the steel column, in.² (m²)
- D = Density of concrete masonry protection, pcf (kg/m³)
- p_s = Heated perimeter of steel column, in. (mm)
- k = Thermal conductivity of concrete masonry, Table 6, Btu/hr•ft•°F (W/m•K)
- p = Inner perimeter of concrete masonry protection, in. (mm)
- T_{ea} = Equivalent thickness of concrete masonry protection, in. (mm)

Note: The 2000 International Building Code (IBC) (ref. 11) replaces the first term in the above equation with $0.17(W/p_s)^{0.7}$ English, and $(1.22(W/p_s)^{0.7})$ metric where W is the average weight of the steel column in lb/ft (kg/m). Both forms of the equations yield identical answers.

For more information on steel columns protected by concrete masonry see TEK 7-6 (ref. 10).

Table 6—Properties of Concrete Masonry Units

Density, D pcf (kg/m ³)	Thermal conductivity ¹ , k Btu/hr•ft•°F (W/m•K)
80 (1281)	0.207 (0.358)
85 (1362)	0.228 (0.394)
90 (1442)	0.252 (0.436)
95 (1522)	0.278 (0.481)
100 (1602)	0.308 (0.533)
105 (1682)	0.340 (0.588)
110 (1762)	0.376 (0.650)
115 (1842)	0.416 (0.720)
120 (1922)	0.459 (0.749)
125 (2002)	0.508 (0.879)
130 (2082)	0.561 (0.971)
135 (2162)	0.620 (1.073)
140 (2243)	0.685 (1.186)
145 (2323)	0.758 (1.312)
150 (2403)	0.837 (1.449)

1. Thermal conductivity at 70 °F. °C = (°F-32)(5/9)

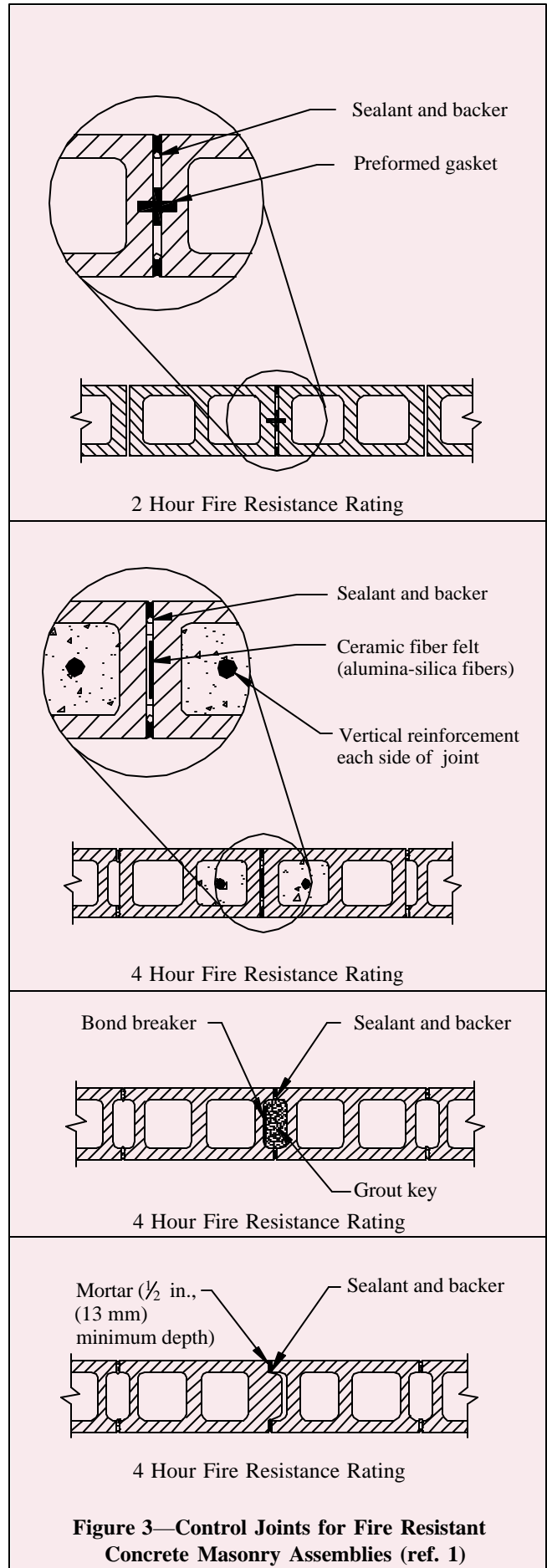
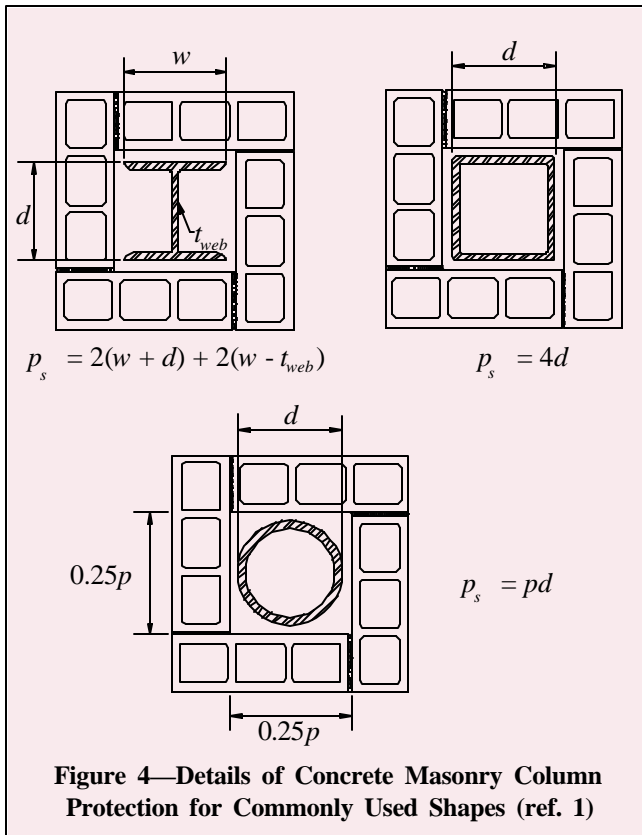

Figure 3—Control Joints for Fire Resistant Concrete Masonry Assemblies (ref. 1)



Effects of Finish Materials

In many cases dry wall, plaster or stucco finishes are added to concrete masonry walls. While finishes are normally applied for architectural reasons, they also provide additional fire resistance value. The Standard (ref. 1) makes provision for calculating the additional fire resistance provided by these finishes.

Type of finish applied to slab or wall	Type of material used in concrete masonry units	
	Siliceous or carbonate aggregate concrete masonry unit	Expanded shale, expanded clay, expanded slag, or pumice less than 20 percent sand
Portland cement-sand plaster ¹ or terrazzo	1.00	0.75
Gypsum-sand plaster	1.25	1.00
Gypsum-vermiculite or perlite plaster	1.75	1.25
Gypsum wall-board	3.00	2.25

1. For portland cement-sand plaster ⁵/₈ in. (16 mm) or less in thickness, and applied directly to concrete masonry on the non-fire-exposed side of the wall, multiplying factor shall be 1.0.

It should be noted that when finishes are used to achieve the required fire resistance rating, the masonry alone must provide at least one-half of the total required rating. This is to assure structural integrity during a fire.

Certain finishes deteriorate more rapidly when exposed to fire than when on the non-fire side of the wall. Therefore, two separate tables are required. Table 7 applies to finishes on the non-fire exposed side of the wall and Table 8 applies to finishes on the fire exposed side.

For finishes on the non-fire exposed side of the wall, the finish is converted to equivalent thickness of concrete masonry by multiplying the thickness of the finish by the factor given in Table 7. This is then added to the base concrete masonry wall equivalent thickness which is used in Table 1 to determine the fire resistance rating.

For finishes on the fire exposed side of the wall, a time is assigned to the finish in Table 8 which is added to the fire resistance rating determined for the base wall and non-fire side finish. The times listed in Table 8 are essentially the length of time the various finishes will remain intact when exposed to fire (on the fire side of the wall).

When calculating the fire resistance rating of a wall with finishes, two calculations are performed. The first is assuming fire on one side of the wall and the second is assuming the fire on the other side. The fire rating of the wall assembly is then the lowest of the two. Note that there may be situations where the wall needs to be rated with the fire on only one side.

Finish description	Time, min
Gypsum wallboard	
³ / ₈ in. (10 mm)	10
¹ / ₂ in. (13 mm)	15
⁵ / ₈ in. (16 mm)	20
Two layers of ³ / ₈ in. (10 mm)	25
One layer of ³ / ₈ in. (10mm) and one layer of ¹ / ₂ in. (16mm)	35
Two layers of ¹ / ₂ in. (16 mm)	40
Type “X” gypsum wallboard	
¹ / ₂ in. (13 mm)	25
⁵ / ₈ in. (16 mm)	40
Direct-applied portland cement-sand plaster	See Note 1
Portland cement-sand plaster on metal lath	
³ / ₄ in. (19 mm)	20
⁷ / ₈ in. (22 mm)	25
1 in. (25 mm)	30
Gypsum-sand plaster on ³ / ₈ in. (10 mm) gypsum lath	
¹ / ₂ in. (13 mm)	35
⁵ / ₈ in. (16 mm)	40
³ / ₄ in. (22 mm)	50
Gypsum-sand plaster on metal lath	
³ / ₄ in. (19 mm)	50
⁷ / ₈ in. (22 mm)	60
1 in. (25 mm)	80

1. For purposes of determining the contribution of portland cement-sand plaster to the equivalent thickness of concrete or masonry for use in Table 1, it shall be permitted to use the actual thickness of the plaster, or ⁵/₈ in. (16 mm), whichever is smaller.

Installation of Finishes

Finishes that are assumed to contribute to the total fire resistance rating of a wall must meet certain minimum installation requirements. Plaster and stucco need only be applied in accordance with the provisions of the building code. Gypsum wallboard and gypsum lath may be attached to wood or metal furring strips spaced a maximum of 24 in. (610 mm) on center or may be attached directly to the wall with adhesives. Drywall and furring may be attached in one of two ways:

- 1). Self-tapping drywall screws spaced a maximum of 12 in. (305 mm) and penetrating a minimum of $\frac{3}{8}$ in. (10 mm) into resilient steel furring channels running horizontally and spaced a maximum of 24 in. (610 mm) on center.
- 2). Lath nails spaced at 12 in. (305 mm) on center maximum, penetrating $\frac{3}{4}$ in. (19 mm) into nominal 1 x 2 in. (25 x 51 mm) wood furring strips which are attached to the masonry with 2 in. (51 mm) concrete nails spaced a maximum of 16 in. (41 mm) on center.

REFERENCES

1. *Standard Method for Determining Fire Resistance of Concrete and Masonry Construction Assemblies*, ACI 216.1-97/TMS 0216.1-97. American Concrete Institute and The Masonry Society, 1997.
2. *Standard Methods for Sampling and Testing Concrete Masonry Units*, ASTM C 140-02a. American Society for Testing and Materials, 2002.
3. *Standard Specification for Concrete Aggregates*, ASTM C 33-02a. American Society for Testing and Materials, 2002.
4. *Standard Specification for Lightweight Aggregates for Concrete Masonry Units*, ASTM C 331-02. American Society for Testing and Materials, 2002.
5. *Standard Specification for Lightweight Aggregates for Insulating Concrete*, ASTM C 332-99. American Society for Testing and Materials, 1999.
6. *Standard Specification for Loadbearing Concrete Masonry Units*, ASTM C 90-02. American Society for Testing and Materials, 2002.
7. *Standard Test Methods for Fire Tests of Building Construction and Materials*, ASTM E 119-00a. American Society for Testing and Materials, 2000.
8. *Standard Specification for Vermiculite Loose Fill Thermal Insulation*, ASTM C 516-02(1996)^{e1}. American Society for Testing and Materials, 2002.
9. *Standard Specification for Perlite Loose Fill Insulation*, ASTM C 549-02. American Society for Testing and Materials, 2002.
10. *Steel Column Fire Protection*, TEK 7-6. National Concrete Masonry Association, 2003.
11. *2000 International Building Code*, Falls Church, Va. International Code Council, 2000.

Gypsum wallboard must be installed with the long dimension parallel to the furring members and all horizontal and vertical joints must be supported and finished. The only exception is $\frac{5}{8}$ in. (16 mm) Type "X" gypsum wallboard which may be installed horizontally without being supported at the horizontal joints.

For drywall attached by the adhesive method, a $\frac{3}{8}$ in. (10 mm) bead of panel adhesive must be placed around the perimeter of the wallboard and across the diagonals and then secured with a masonry nail for each 2 ft² (0.19 m²) of panel.

CONCLUSION

The calculated fire resistance procedure is practical, versatile, and economical. It is based on thousands of tests. It is incorporated by reference into the major model codes of the US and allows the designer virtually unlimited flexibility to incorporate the excellent fire resistive properties of concrete masonry into the design.

Provided by:
Cinder & Concrete Block Corporation

Disclaimer: NCMA and the companies disseminating this technical information disclaim any and all responsibility and liability for the accuracy and the application of the information contained in this publication.