

SPAN TABLES FOR JOISTS AND RAFTERS

2005 EDITION

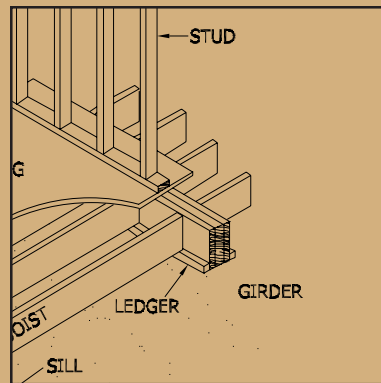
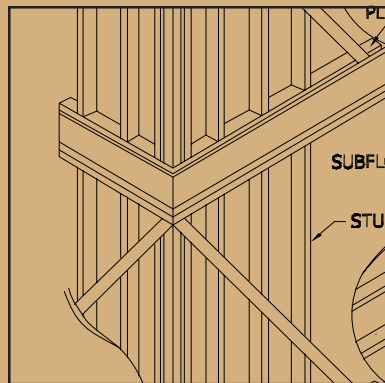
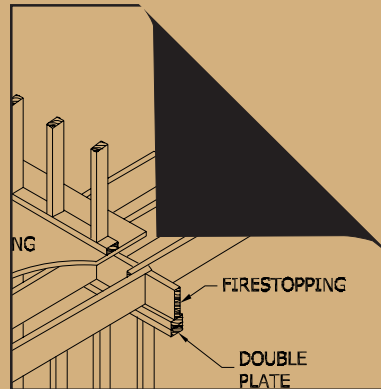
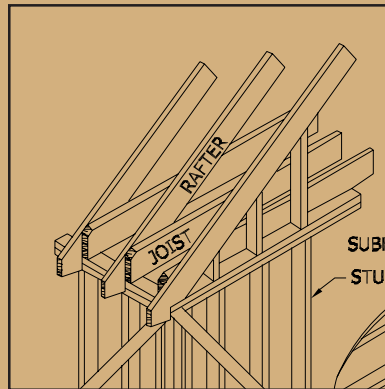

American Softwood Lumber
Standard (PS 20-05) Sizes

American
Forest &
Paper
Association

SPAN TABLES FOR JOISTS AND RAFTERS

2005 EDITION

The American Wood Council (AWC) is the wood products division of the American Forest & Paper Association (AF&PA). AF&PA is the national trade association of the forest, paper, and wood products industry, representing member companies engaged in growing, harvesting, and processing wood and wood fiber, manufacturing pulp, paper, and paperboard products from both virgin and recycled fiber, and producing engineered and traditional wood products. For more information see www.afandpa.org.

While every effort has been made to insure the accuracy of the information presented, and special effort has been made to assure that the information reflects the state-of-the-art, neither the American Forest & Paper Association nor its members assume any responsibility for any particular design prepared from this publication. Those using this document assume all liability from its use.

Copyright © 1993, 2006
American Forest & Paper Association, Inc.

American Wood Council
1111 19th St., NW, Suite 800
Washington, DC 20036
202-463-4713
awcinfo@afandpa.org
www.awc.org

TABLE OF CONTENTS

Table No.	Description of Tables	Page
	Explanation of Tables	1
 FLOOR JOISTS WITH L/360 DEFLECTION LIMITS		
F-1	Live Load of 30 psf plus dead load of 10 psf	4
F-2	Live Load of 40 psf plus dead load of 10 psf	5
F-3	Live Load of 50 psf plus dead load of 10 psf	6
F-4	Live Load of 60 psf plus dead load of 10 psf	7
F-5	Live Load of 40 psf plus dead load of 20 psf	8
F-6	Live Load of 50 psf plus dead load of 20 psf	9
F-7	Live Load of 60 psf plus dead load of 20 psf	10
 CEILING JOISTS WITH L/240 DEFLECTION LIMITS		
C-1	Live Load of 10 psf plus dead load of 5 psf	11
C-2	Live Load of 20 psf plus dead load of 10 psf	12
 RAFTERS WITH L/240 DEFLECTION LIMITS		
R-1	Live Load of 20 psf plus dead load of 10 psf	13
R-2	Live Load of 30 psf plus dead load of 10 psf	14
R-3	Live Load of 40 psf plus dead load of 10 psf	15
R-4	Live Load of 50 psf plus dead load of 10 psf	16
R-5	Live Load of 20 psf plus dead load of 15 psf	17
R-6	Live Load of 30 psf plus dead load of 15 psf	18
R-7	Live Load of 40 psf plus dead load of 15 psf	19
R-8	Live Load of 50 psf plus dead load of 15 psf	20
R-9	Live Load of 20 psf plus dead load of 20 psf	21
R-10	Live Load of 30 psf plus dead load of 20 psf	22
R-11	Live Load of 40 psf plus dead load of 20 psf	23
R-12	Live Load of 50 psf plus dead load of 20 psf	24
 RAFTERS WITH L/180 DEFLECTION LIMITS		
R-13	Live Load of 20 psf plus dead load of 10 psf	25
R-14	Live Load of 30 psf plus dead load of 10 psf	26
R-15	Live Load of 40 psf plus dead load of 10 psf	27
R-16	Live Load of 50 psf plus dead load of 10 psf	28
R-17	Live Load of 20 psf plus dead load of 15 psf	29
R-18	Live Load of 30 psf plus dead load of 15 psf	30
R-19	Live Load of 40 psf plus dead load of 15 psf	31
R-20	Live Load of 50 psf plus dead load of 15 psf	32
R-21	Live Load of 20 psf plus dead load of 20 psf	33
R-22	Live Load of 30 psf plus dead load of 20 psf	34
R-23	Live Load of 40 psf plus dead load of 20 psf	35
R-24	Live Load of 50 psf plus dead load of 20 psf	36
	Commentary	A-1

EXPLANATION OF TABLES

1. SCOPE

These span tables for joists and rafters are calculated on the basis of a series of modulus of elasticity (E) and bending design values (F_b). Additionally, compression perpendicular to grain design values ($F_{c\perp}$) are included as a consideration for selection of joists and rafters. The range of values in the tables provides allowable spans for all species and grades of nominal 2-inch framing lumber customarily used in construction. These span tables assume installation of at least three joists or rafters that are spaced not more than 24" on center. The calculated spans assume fully supported members, properly sheathed and nailed on the top edge of the joist or rafter. Straight-line interpolation shall be permitted for intermediate spans and design values.

2. LUMBER DESIGN VALUES

Use of these span tables requires reference to the applicable design values for the various species and grades of lumber. Tables W-1 and W-2 of *Design Values for Joists and Rafters*, a supplement to these span tables, provide such values for the most commonly used framing sizes. Modulus of elasticity (E), bending design values (F_b), and compression design values perpendicular to grain ($F_{c\perp}$) therein are based on the *National Design Specification® (NDS®) for Wood Construction* and incorporate adjustments appropriate for repetitive-member use under various durations of load.

3. LUMBER SIZES

Tabulated spans apply to surfaced (S4S) lumber having dimensions which conform to the American Softwood Lumber Standard, PS 20-05. These sizes are as follows:

Nominal Size	Actual Surfaced Dry Size
2 x 4	1-1/2 x 3-1/2
2 x 6	1-1/2 x 5-1/2
2 x 8	1-1/2 x 7-1/4
2 x 10	1-1/2 x 9-1/4
2 x 12	1-1/2 x 11-1/4

4. MOISTURE CONTENT

The listed dry sizes are based on lumber at 19 percent maximum moisture content. Since the change in dimension that occurs in wet service conditions has already been accounted for in the fully adjusted design value, tabulated spans are applicable to lumber in dry or wet service conditions.

5. SPAN MEASUREMENT

Tabulated spans are the distance from face to face of supports. For sloping rafters the span is measured along the horizontal projection. The commentary provides further information on span measurements including a chart which converts horizontal distances to sloping distances, or vice versa.

6. ROOF LOADS

Rafter spans are tabulated for the most common roof loads. The loads are based on adjusted roof snow loads from the governing building code. For roof live loads less than 20 pounds per square foot (psf), rafter spans and required E values tabulated for 20 psf shall be permitted to be adjusted in accordance with the following table:

Table number	For roof live loads of 12 psf or 16 psf			
	Multiply tabulated span by		Multiply required E-value by	
	12 psf	16 psf	12 psf	16 psf
R-1	1.17	1.07	0.96	0.99
R-5	1.14	1.06	0.89	0.96
R-9	1.12	1.05	0.84	0.94
R-13	1.17	1.07	0.96	0.99
R-17	1.14	1.06	0.89	0.96
R-21	1.12	1.05	0.84	0.94
For intermediate values of roof live loads, use straight line interpolation.				

7. LUMBER IDENTIFICATION

The tabulated spans in these tables apply to lumber identified by the grade stamp of, or certificate of inspection issued by, a lumber grading or inspection bureau or agency recognized as being competent by the Board of Review of the American Lumber Standard Committee or the Canadian Lumber Standards Accreditation Board.

8. GENERAL REQUIREMENTS

The quality of wood products and fasteners and the design of load-supporting members and connections shall conform to the *NDS*. All members shall be so framed, anchored, tied, and braced that they have the necessary strength and rigidity. Adequate bracing and bridging to resist wind and other lateral forces shall be provided.

9. REQUIRED COMPRESSION PERPENDICULAR TO GRAIN

The required compression perpendicular to grain design value, $F_{c\perp}$, for the joist or rafter shall be determined from Table 9.1. The table assumes a total load of 66.67 plf on the joist or rafter. The required $F_{c\perp}$ value shall be permitted to be adjusted in direct proportion to alternate total loads using factors tabulated in Table 9.2. The commentary outlines several examples that include provisions for determining required compression perpendicular to grain design values.

Table 9.1 Required compression perpendicular to grain design values ($F_{c\perp}$) in pounds per square inch for simple span joists and rafters with uniform load.

Span, ft	Bearing Length, in.				
	1.5	2.0	2.5	3.0	3.5
2	30	22	18	15	13
4	59	44	36	30	25
6	89	67	53	44	38
8	119	89	71	59	51
10	148	111	89	74	63
12	178	133	107	89	76
14	207	156	124	104	89
16	237	178	142	119	102
18	267	200	160	133	114
20	296	222	178	148	127
22	326	244	196	163	140
24	356	267	213	178	152
26	385	289	231	193	165

Notes: 1) Bearing width is assumed to be 1.5".
 2) Total uniform load is assumed to be 66.67 plf.
 3) Alternate $F_{c\perp}$ values are possible by adjusting the tabulated values in direct proportion to the desired load. Adjustment factors are tabulated in Table 9.2.
 4) See A.1.3 for 2 span floor joist requirements.

Table 9.2 Adjustment factors for alternate loading and spacing conditions for determining required compression perpendicular to grain design values ($F_{c\perp}$) for joists and rafters.

Loads, psf		On-center spacing, in.			
Live	Dead	12	16	19.2	24
10	5	0.23	0.30	0.36	0.45
20	10	0.45	0.60	0.72	0.90
30	10	0.60	0.80	0.96	1.20
40	10	0.75	1.00	1.20	1.50
50	10	0.90	1.20	1.44	1.80
60	10	1.05	1.40	1.68	2.10
20	15	0.53	0.70	0.84	1.05
30	15	0.68	0.90	1.08	1.35
40	15	0.83	1.10	1.32	1.65
50	15	0.98	1.30	1.56	1.95
20	20	0.60	0.80	0.96	1.20
30	20	0.75	1.00	1.20	1.50
40	20	0.90	1.20	1.44	1.80
50	20	1.05	1.40	1.68	2.10
60	20	1.20	1.60	1.92	2.40

Note: Multiply Table 9.1 values by adjustment factors to obtain required compression perpendicular to grain design values.

TABLE F-1
FLOOR JOISTS WITH L/360 DEFLECTION LIMITS

DESIGN CRITERIA:
Deflection - For 30 psf live load.
Limited to span in inches divided by 360.
Strength - Live load of 30 psf plus dead load
of 10 psf determines the required bending design value.

Joist Size (in)	Spacing (in)	Modulus of Elasticity, E, in 1,000,000 psi																
		0.8	0.9	1.0	1.1	1.2	1.3	1.4	1.5	1.6	1.7	1.8	1.9	2.0	2.1	2.2	2.3	2.4
2x 6	12.0	9 - 4	9 - 9	10 - 1	10 - 5	10 - 9	11 - 0	11 - 3	11 - 7	11 - 10	12 - 0	12 - 3	12 - 6	12 - 9	12 - 11	13 - 1	13 - 4	13 - 6
	16.0	8 - 6	8 - 10	9 - 2	9 - 6	9 - 9	10 - 0	10 - 3	10 - 6	10 - 9	10 - 11	11 - 2	11 - 4	11 - 7	11 - 9	11 - 11	12 - 1	12 - 3
	19.2	8 - 0	8 - 4	8 - 8	8 - 11	9 - 2	9 - 5	9 - 8	9 - 10	10 - 1	10 - 4	10 - 6	10 - 8	10 - 10	11 - 1	11 - 3	11 - 5	11 - 7
	24.0	7 - 5	7 - 9	8 - 0	8 - 3	8 - 6	8 - 9	8 - 11	9 - 2	9 - 4	9 - 7	9 - 9	9 - 11	10 - 1	10 - 3	10 - 5	10 - 7	10 - 9
2x 8	12.0	12 - 4	12 - 10	13 - 4	13 - 9	14 - 2	14 - 6	14 - 11	15 - 3	15 - 7	15 - 10	16 - 2	16 - 6	16 - 9	17 - 0	17 - 4	17 - 7	17 - 10
	16.0	11 - 3	11 - 8	12 - 1	12 - 6	12 - 10	13 - 2	13 - 6	13 - 10	14 - 2	14 - 5	14 - 8	15 - 0	15 - 3	15 - 6	15 - 9	15 - 11	16 - 2
	19.2	10 - 7	11 - 0	11 - 4	11 - 9	12 - 1	12 - 5	12 - 9	13 - 0	13 - 4	13 - 7	13 - 10	14 - 1	14 - 4	14 - 7	14 - 9	15 - 0	15 - 3
	24.0	9 - 10	10 - 2	10 - 7	10 - 11	11 - 3	11 - 6	11 - 10	12 - 1	12 - 4	12 - 7	12 - 10	13 - 1	13 - 4	13 - 6	13 - 9	13 - 11	14 - 2
2x10	12.0	15 - 9	16 - 5	17 - 0	17 - 6	18 - 0	18 - 6	19 - 0	19 - 5	19 - 10	20 - 3	20 - 8	21 - 0	21 - 5	21 - 9	22 - 1	22 - 5	22 - 9
	16.0	14 - 4	14 - 11	15 - 5	15 - 11	16 - 5	16 - 10	17 - 3	17 - 8	18 - 0	18 - 5	18 - 9	19 - 1	19 - 5	19 - 9	20 - 1	20 - 4	20 - 8
	19.2	13 - 6	14 - 0	14 - 6	15 - 0	15 - 5	15 - 10	16 - 3	16 - 7	17 - 0	17 - 4	17 - 8	18 - 0	18 - 3	18 - 7	18 - 10	19 - 2	19 - 5
	24.0	12 - 6	13 - 0	13 - 6	13 - 11	14 - 4	14 - 8	15 - 1	15 - 5	15 - 9	16 - 1	16 - 5	16 - 8	17 - 0	17 - 3	17 - 6	17 - 9	18 - 0
2x12	12.0	19 - 2	19 - 11	20 - 8	21 - 4	21 - 11	22 - 6	23 - 1	23 - 7	24 - 2	24 - 8	25 - 1	25 - 7	26 - 0	-	-	-	-
	16.0	17 - 5	18 - 1	18 - 9	19 - 4	19 - 11	20 - 6	21 - 0	21 - 6	21 - 11	22 - 5	22 - 10	23 - 3	23 - 7	24 - 0	24 - 5	24 - 9	25 - 1
	19.2	16 - 5	17 - 0	17 - 8	18 - 3	18 - 9	19 - 3	19 - 9	20 - 2	20 - 8	21 - 1	21 - 6	21 - 10	22 - 3	22 - 7	22 - 11	23 - 3	23 - 7
	24.0	15 - 2	15 - 10	16 - 5	16 - 11	17 - 5	17 - 11	18 - 4	18 - 9	19 - 2	19 - 7	19 - 11	20 - 3	20 - 8	21 - 0	21 - 4	21 - 7	21 - 11
F _b	12.0	696	753	808	861	912	962	1,011	1,058	1,105	1,150	1,195	1,239	1,282	1,324	1,366	1,407	1,448
	16.0	766	829	889	947	1,004	1,059	1,112	1,165	1,216	1,266	1,315	1,364	1,411	1,458	1,504	1,549	1,593
	19.2	814	881	945	1,007	1,067	1,125	1,182	1,238	1,292	1,345	1,398	1,449	1,499	1,549	1,598	1,646	1,693
	24.0	877	949	1,018	1,084	1,149	1,212	1,273	1,333	1,392	1,449	1,506	1,561	1,615	1,669	1,721	1,773	1,824

Note: The required bending design value, F_b, in pounds per square inch is shown at the bottom of each table and is applicable to all lumber sizes shown. Spans are shown in feet-inches and are limited to 26' and less. Check sources of supply for availability of lumber in lengths greater than 20'.

**TABLE F-2
FLOOR JOISTS WITH L/360 DEFLECTION LIMITS**

DESIGN CRITERIA:
 Deflection - For 40 psf live load.
 Limited to span in inches divided by 360.
 Strength - Live load of 40 psf plus dead load
 of 10 psf determines the required bending design value.

Joist Size (in)	Spacing (in)	Modulus of Elasticity, E, in 1,000,000 psi																
		0.8	0.9	1.0	1.1	1.2	1.3	1.4	1.5	1.6	1.7	1.8	1.9	2.0	2.1	2.2	2.3	2.4
2x 6	12.0	8 - 6	8 - 10	9 - 2	9 - 6	9 - 9	10 - 0	10 - 3	10 - 6	10 - 9	10 - 11	11 - 2	11 - 4	11 - 7	11 - 9	11 - 11	12 - 1	12 - 3
	16.0	7 - 9	8 - 0	8 - 4	8 - 7	8 - 10	9 - 1	9 - 4	9 - 6	9 - 9	9 - 11	10 - 2	10 - 4	10 - 6	10 - 8	10 - 10	11 - 0	11 - 2
	19.2	7 - 3	7 - 7	7 - 10	8 - 1	8 - 4	8 - 7	8 - 9	9 - 0	9 - 2	9 - 4	9 - 6	9 - 8	9 - 10	10 - 0	10 - 2	10 - 4	10 - 6
	24.0	6 - 9	7 - 0	7 - 3	7 - 6	7 - 9	7 - 11	8 - 2	8 - 4	8 - 6	8 - 8	8 - 10	9 - 0	9 - 2	9 - 4	9 - 6	9 - 7	9 - 9
2x 8	12.0	11 - 3	11 - 8	12 - 1	12 - 6	12 - 10	13 - 2	13 - 6	13 - 10	14 - 2	14 - 5	14 - 8	15 - 0	15 - 3	15 - 6	15 - 9	15 - 11	16 - 2
	16.0	10 - 2	10 - 7	11 - 0	11 - 4	11 - 8	12 - 0	12 - 3	12 - 7	12 - 10	13 - 1	13 - 4	13 - 7	13 - 10	14 - 1	14 - 3	14 - 6	14 - 8
	19.2	9 - 7	10 - 0	10 - 4	10 - 8	11 - 0	11 - 3	11 - 7	11 - 10	12 - 1	12 - 4	12 - 7	12 - 10	13 - 0	13 - 3	13 - 5	13 - 8	13 - 10
	24.0	8 - 11	9 - 3	9 - 7	9 - 11	10 - 2	10 - 6	10 - 9	11 - 0	11 - 3	11 - 5	11 - 8	11 - 11	12 - 1	12 - 3	12 - 6	12 - 8	12 - 10
2x10	12.0	14 - 4	14 - 11	15 - 5	15 - 11	16 - 5	16 - 10	17 - 3	17 - 8	18 - 0	18 - 5	18 - 9	19 - 1	19 - 5	19 - 9	20 - 1	20 - 4	20 - 8
	16.0	13 - 0	13 - 6	14 - 0	14 - 6	14 - 11	15 - 3	15 - 8	16 - 0	16 - 5	16 - 9	17 - 0	17 - 4	17 - 8	17 - 11	18 - 3	18 - 6	18 - 9
	19.2	12 - 3	12 - 9	13 - 2	13 - 7	14 - 0	14 - 5	14 - 9	15 - 1	15 - 5	15 - 9	16 - 0	16 - 4	16 - 7	16 - 11	17 - 2	17 - 5	17 - 8
	24.0	11 - 4	11 - 10	12 - 3	12 - 8	13 - 0	13 - 4	13 - 8	14 - 0	14 - 4	14 - 7	14 - 11	15 - 2	15 - 5	15 - 8	15 - 11	16 - 2	16 - 5
2x12	12.0	17 - 5	18 - 1	18 - 9	19 - 4	19 - 11	20 - 6	21 - 0	21 - 6	21 - 11	22 - 5	22 - 10	23 - 3	23 - 7	24 - 0	24 - 5	24 - 9	25 - 1
	16.0	15 - 10	16 - 5	17 - 0	17 - 7	18 - 1	18 - 7	19 - 1	19 - 6	19 - 11	20 - 4	20 - 9	21 - 1	21 - 6	21 - 10	22 - 2	22 - 6	22 - 10
	19.2	14 - 11	15 - 6	16 - 0	16 - 7	17 - 0	17 - 6	17 - 11	18 - 4	18 - 9	19 - 2	19 - 6	19 - 10	20 - 2	20 - 6	20 - 10	21 - 2	21 - 6
	24.0	13 - 10	14 - 4	14 - 11	15 - 4	15 - 10	16 - 3	16 - 8	17 - 0	17 - 5	17 - 9	18 - 1	18 - 5	18 - 9	19 - 1	19 - 4	19 - 8	19 - 11
F _b	12.0	718	777	833	888	941	993	1,043	1,092	1,140	1,187	1,233	1,278	1,323	1,367	1,410	1,452	1,494
	16.0	790	855	917	977	1,036	1,093	1,148	1,202	1,255	1,306	1,357	1,407	1,456	1,504	1,551	1,598	1,644
	19.2	840	909	975	1,039	1,101	1,161	1,220	1,277	1,333	1,388	1,442	1,495	1,547	1,598	1,649	1,698	1,747
	24.0	905	979	1,050	1,119	1,186	1,251	1,314	1,376	1,436	1,496	1,554	1,611	1,667	1,722	1,776	1,829	1,882

Note: The required bending design value, F_b, in pounds per square inch is shown at the bottom of each table and is applicable to all lumber sizes shown. Spans are shown in feet-inches and are limited to 26' and less. Check sources of supply for availability of lumber in lengths greater than 20'.

TABLE F-3
FLOOR JOISTS WITH L/360 DEFLECTION LIMITS

DESIGN CRITERIA:
Deflection - For 50 psf live load.
Limited to span in inches divided by 360.
Strength - Live load of 50 psf plus dead load
of 10 psf determines the required bending design value.

Joist Size (in)	Spacing (in)	Modulus of Elasticity, E, in 1,000,000 psi																
		0.8	0.9	1.0	1.1	1.2	1.3	1.4	1.5	1.6	1.7	1.8	1.9	2.0	2.1	2.2	2.3	2.4
2x 6	12.0	7 - 11	8 - 3	8 - 6	8 - 9	9 - 1	9 - 3	9 - 6	9 - 9	9 - 11	10 - 2	10 - 4	10 - 6	10 - 9	10 - 11	11 - 1	11 - 3	11 - 5
	16.0	7 - 2	7 - 6	7 - 9	8 - 0	8 - 3	8 - 5	8 - 8	8 - 10	9 - 1	9 - 3	9 - 5	9 - 7	9 - 9	9 - 11	10 - 1	10 - 2	10 - 4
	19.2	6 - 9	7 - 0	7 - 3	7 - 6	7 - 9	7 - 11	8 - 2	8 - 4	8 - 6	8 - 8	8 - 10	9 - 0	9 - 2	9 - 4	9 - 6	9 - 7	9 - 9
	24.0	6 - 3	6 - 6	6 - 9	7 - 0	7 - 2	7 - 4	7 - 7	7 - 9	7 - 11	8 - 1	8 - 3	8 - 4	8 - 6	8 - 8	8 - 9	8 - 11	9 - 1
2x 8	12.0	10 - 5	10 - 10	11 - 3	11 - 7	11 - 11	12 - 3	12 - 7	12 - 10	13 - 1	13 - 5	13 - 8	13 - 11	14 - 2	14 - 4	14 - 7	14 - 10	15 - 0
	16.0	9 - 6	9 - 10	10 - 2	10 - 6	10 - 10	11 - 1	11 - 5	11 - 8	11 - 11	12 - 2	12 - 5	12 - 7	12 - 10	13 - 1	13 - 3	13 - 5	13 - 8
	19.2	8 - 11	9 - 3	9 - 7	9 - 11	10 - 2	10 - 6	10 - 9	11 - 0	11 - 3	11 - 5	11 - 8	11 - 11	12 - 1	12 - 3	12 - 6	12 - 8	12 - 10
	24.0	8 - 3	8 - 7	8 - 11	9 - 2	9 - 6	9 - 9	10 - 0	10 - 2	10 - 5	10 - 8	10 - 10	11 - 0	11 - 3	11 - 5	11 - 7	11 - 9	11 - 11
2x10	12.0	13 - 3	13 - 10	14 - 4	14 - 9	15 - 2	15 - 7	16 - 0	16 - 5	16 - 9	17 - 1	17 - 5	17 - 9	18 - 0	18 - 4	18 - 7	18 - 11	19 - 2
	16.0	12 - 1	12 - 7	13 - 0	13 - 5	13 - 10	14 - 2	14 - 7	14 - 11	15 - 2	15 - 6	15 - 10	16 - 1	16 - 5	16 - 8	16 - 11	17 - 2	17 - 5
	19.2	11 - 4	11 - 10	12 - 3	12 - 8	13 - 0	13 - 4	13 - 8	14 - 0	14 - 4	14 - 7	14 - 11	15 - 2	15 - 5	15 - 8	15 - 11	16 - 2	16 - 5
	24.0	10 - 7	11 - 0	11 - 4	11 - 9	12 - 1	12 - 5	12 - 8	13 - 0	13 - 3	13 - 7	13 - 10	14 - 1	14 - 4	14 - 7	14 - 9	15 - 0	15 - 2
2x12	12.0	16 - 2	16 - 10	17 - 5	18 - 0	18 - 6	19 - 0	19 - 6	19 - 11	20 - 4	20 - 9	21 - 2	21 - 7	21 - 11	22 - 3	22 - 8	23 - 0	23 - 4
	16.0	14 - 8	15 - 3	15 - 10	16 - 4	16 - 10	17 - 3	17 - 8	18 - 1	18 - 6	18 - 10	19 - 3	19 - 7	19 - 11	20 - 3	20 - 7	20 - 11	21 - 2
	19.2	13 - 10	14 - 4	14 - 11	15 - 4	15 - 10	16 - 3	16 - 8	17 - 0	17 - 5	17 - 9	18 - 1	18 - 5	18 - 9	19 - 1	19 - 4	19 - 8	19 - 11
	24.0	12 - 10	13 - 4	13 - 10	14 - 3	14 - 8	15 - 1	15 - 5	15 - 10	16 - 2	16 - 6	16 - 10	17 - 1	17 - 5	17 - 8	18 - 0	18 - 3	18 - 6
F _b	12.0	743	803	862	918	973	1,026	1,078	1,129	1,179	1,228	1,275	1,322	1,368	1,413	1,458	1,502	1,545
	16.0	817	884	949	1,011	1,071	1,130	1,187	1,243	1,298	1,351	1,404	1,455	1,506	1,555	1,604	1,653	1,700
	19.2	869	940	1,008	1,074	1,138	1,201	1,261	1,321	1,379	1,436	1,491	1,546	1,600	1,653	1,705	1,756	1,807
	24.0	936	1,012	1,086	1,157	1,226	1,293	1,359	1,423	1,485	1,547	1,607	1,666	1,724	1,781	1,837	1,892	1,946

Note: The required bending design value, F_b, in pounds per square inch is shown at the bottom of each table and is applicable to all lumber sizes shown. Spans are shown in feet-inches and are limited to 26' and less. Check sources of supply for availability of lumber in lengths greater than 20'.

**TABLE F-4
FLOOR JOISTS WITH L/360 DEFLECTION LIMITS**

DESIGN CRITERIA:
 Deflection - For 60 psf live load.
 Limited to span in inches divided by 360.
 Strength - Live load of 60 psf plus dead load
 of 10 psf determines the required bending design value.

Joist Size (in)	Spacing (in)	Modulus of Elasticity, E, in 1,000,000 psi																
		0.8	0.9	1.0	1.1	1.2	1.3	1.4	1.5	1.6	1.7	1.8	1.9	2.0	2.1	2.2	2.3	2.4
2x 6	12.0	7 - 5	7 - 9	8 - 0	8 - 3	8 - 6	8 - 9	8 - 11	9 - 2	9 - 4	9 - 7	9 - 9	9 - 11	10 - 1	10 - 3	10 - 5	10 - 7	10 - 9
	16.0	6 - 9	7 - 0	7 - 3	7 - 6	7 - 9	7 - 11	8 - 2	8 - 4	8 - 6	8 - 8	8 - 10	9 - 0	9 - 2	9 - 4	9 - 6	9 - 7	9 - 9
	19.2	6 - 4	6 - 7	6 - 10	7 - 1	7 - 3	7 - 6	7 - 8	7 - 10	8 - 0	8 - 2	8 - 4	8 - 6	8 - 8	8 - 9	8 - 11	9 - 0	9 - 2
	24.0	5 - 11	6 - 2	6 - 4	6 - 7	6 - 9	6 - 11	7 - 1	7 - 3	7 - 5	7 - 7	7 - 9	7 - 10	8 - 0	8 - 2	8 - 3	8 - 5	8 - 6
2x 8	12.0	9 - 10	10 - 2	10 - 7	10 - 11	11 - 3	11 - 6	11 - 10	12 - 1	12 - 4	12 - 7	12 - 10	13 - 1	13 - 4	13 - 6	13 - 9	13 - 11	14 - 2
	16.0	8 - 11	9 - 3	9 - 7	9 - 11	10 - 2	10 - 6	10 - 9	11 - 0	11 - 3	11 - 5	11 - 8	11 - 11	12 - 1	12 - 3	12 - 6	12 - 8	12 - 10
	19.2	8 - 5	8 - 9	9 - 0	9 - 4	9 - 7	9 - 10	10 - 1	10 - 4	10 - 7	10 - 9	11 - 0	11 - 2	11 - 4	11 - 7	11 - 9	11 - 11	12 - 1
	24.0	7 - 9	8 - 1	8 - 5	8 - 8	8 - 11	9 - 2	9 - 4	9 - 7	9 - 10	10 - 0	10 - 2	10 - 5	10 - 7	10 - 9	10 - 11	11 - 1	11 - 3
2x10	12.0	12 - 6	13 - 0	13 - 6	13 - 11	14 - 4	14 - 8	15 - 1	15 - 5	15 - 9	16 - 1	16 - 5	16 - 8	17 - 0	17 - 3	17 - 6	17 - 9	18 - 0
	16.0	11 - 4	11 - 10	12 - 3	12 - 8	13 - 0	13 - 4	13 - 8	14 - 0	14 - 4	14 - 7	14 - 11	15 - 2	15 - 5	15 - 8	15 - 11	16 - 2	16 - 5
	19.2	10 - 8	11 - 1	11 - 6	11 - 11	12 - 3	12 - 7	12 - 11	13 - 2	13 - 6	13 - 9	14 - 0	14 - 3	14 - 6	14 - 9	15 - 0	15 - 2	15 - 5
	24.0	9 - 11	10 - 4	10 - 8	11 - 0	11 - 4	11 - 8	11 - 11	12 - 3	12 - 6	12 - 9	13 - 0	13 - 3	13 - 6	13 - 8	13 - 11	14 - 1	14 - 4
2x12	12.0	15 - 2	15 - 10	16 - 5	16 - 11	17 - 5	17 - 11	18 - 4	18 - 9	19 - 2	19 - 7	19 - 11	20 - 3	20 - 8	21 - 0	21 - 4	21 - 7	21 - 11
	16.0	13 - 10	14 - 4	14 - 11	15 - 4	15 - 10	16 - 3	16 - 8	17 - 0	17 - 5	17 - 9	18 - 1	18 - 5	18 - 9	19 - 1	19 - 4	19 - 8	19 - 11
	19.2	13 - 0	13 - 6	14 - 0	14 - 5	14 - 11	15 - 3	15 - 8	16 - 0	16 - 5	16 - 9	17 - 0	17 - 4	17 - 8	17 - 11	18 - 3	18 - 6	18 - 9
	24.0	12 - 1	12 - 7	13 - 0	13 - 5	13 - 10	14 - 2	14 - 7	14 - 11	15 - 2	15 - 6	15 - 10	16 - 1	16 - 5	16 - 8	16 - 11	17 - 2	17 - 5
F _b	12.0	767	830	890	949	1,005	1,061	1,114	1,167	1,218	1,268	1,317	1,366	1,413	1,460	1,506	1,551	1,596
	16.0	844	913	980	1,044	1,107	1,167	1,226	1,284	1,341	1,396	1,450	1,503	1,556	1,607	1,658	1,707	1,757
	19.2	897	971	1,041	1,110	1,176	1,240	1,303	1,365	1,425	1,483	1,541	1,597	1,653	1,708	1,761	1,814	1,867
	24.0	967	1,046	1,122	1,195	1,267	1,336	1,404	1,470	1,535	1,598	1,660	1,721	1,781	1,840	1,897	1,955	2,011

Note: The required bending design value, F_b, in pounds per square inch is shown at the bottom of each table and is applicable to all lumber sizes shown. Spans are shown in feet-inches and are limited to 26' and less. Check sources of supply for availability of lumber in lengths greater than 20'.

TABLE F-5
FLOOR JOISTS WITH L/360 DEFLECTION LIMITS

DESIGN CRITERIA:
Deflection - For 40 psf live load.
Limited to span in inches divided by 360.
Strength - Live load of 40 psf plus dead load
of 20 psf determines the required bending design value.

Joist Size (in)	Spacing (in)	Modulus of Elasticity, E, in 1,000,000 psi																
		0.8	0.9	1.0	1.1	1.2	1.3	1.4	1.5	1.6	1.7	1.8	1.9	2.0	2.1	2.2	2.3	2.4
2x 6	12.0	8 - 6	8 - 10	9 - 2	9 - 6	9 - 9	10 - 0	10 - 3	10 - 6	10 - 9	10 - 11	11 - 2	11 - 4	11 - 7	11 - 9	11 - 11	12 - 1	12 - 3
	16.0	7 - 9	8 - 0	8 - 4	8 - 7	8 - 10	9 - 1	9 - 4	9 - 6	9 - 9	9 - 11	10 - 2	10 - 4	10 - 6	10 - 8	10 - 10	11 - 0	11 - 2
	19.2	7 - 3	7 - 7	7 - 10	8 - 1	8 - 4	8 - 7	8 - 9	9 - 0	9 - 2	9 - 4	9 - 6	9 - 8	9 - 10	10 - 0	10 - 2	10 - 4	10 - 6
	24.0	6 - 9	7 - 0	7 - 3	7 - 6	7 - 9	7 - 11	8 - 2	8 - 4	8 - 6	8 - 8	8 - 10	9 - 0	9 - 2	9 - 4	9 - 6	9 - 7	9 - 9
2x 8	12.0	11 - 3	11 - 8	12 - 1	12 - 6	12 - 10	13 - 2	13 - 6	13 - 10	14 - 2	14 - 5	14 - 8	15 - 0	15 - 3	15 - 6	15 - 9	15 - 11	16 - 2
	16.0	10 - 2	10 - 7	11 - 0	11 - 4	11 - 8	12 - 0	12 - 3	12 - 7	12 - 10	13 - 1	13 - 4	13 - 7	13 - 10	14 - 1	14 - 3	14 - 6	14 - 8
	19.2	9 - 7	10 - 0	10 - 4	10 - 8	11 - 0	11 - 3	11 - 7	11 - 10	12 - 1	12 - 4	12 - 7	12 - 10	13 - 0	13 - 3	13 - 5	13 - 8	13 - 10
	24.0	8 - 11	9 - 3	9 - 7	9 - 11	10 - 2	10 - 6	10 - 9	11 - 0	11 - 3	11 - 5	11 - 8	11 - 11	12 - 1	12 - 3	12 - 6	12 - 8	12 - 10
2x10	12.0	14 - 4	14 - 11	15 - 5	15 - 11	16 - 5	16 - 10	17 - 3	17 - 8	18 - 0	18 - 5	18 - 9	19 - 1	19 - 5	19 - 9	20 - 1	20 - 4	20 - 8
	16.0	13 - 0	13 - 6	14 - 0	14 - 6	14 - 11	15 - 3	15 - 8	16 - 0	16 - 5	16 - 9	17 - 0	17 - 4	17 - 8	17 - 11	18 - 3	18 - 6	18 - 9
	19.2	12 - 3	12 - 9	13 - 2	13 - 7	14 - 0	14 - 5	14 - 9	15 - 1	15 - 5	15 - 9	16 - 0	16 - 4	16 - 7	16 - 11	17 - 2	17 - 5	17 - 8
	24.0	11 - 4	11 - 10	12 - 3	12 - 8	13 - 0	13 - 4	13 - 8	14 - 0	14 - 4	14 - 7	14 - 11	15 - 2	15 - 5	15 - 8	15 - 11	16 - 2	16 - 5
2x12	12.0	17 - 5	18 - 1	18 - 9	19 - 4	19 - 11	20 - 6	21 - 0	21 - 6	21 - 11	22 - 5	22 - 10	23 - 3	23 - 7	24 - 0	24 - 5	24 - 9	25 - 1
	16.0	15 - 10	16 - 5	17 - 0	17 - 7	18 - 1	18 - 7	19 - 1	19 - 6	19 - 11	20 - 4	20 - 9	21 - 1	21 - 6	21 - 10	22 - 2	22 - 6	22 - 10
	19.2	14 - 11	15 - 6	16 - 0	16 - 7	17 - 0	17 - 6	17 - 11	18 - 4	18 - 9	19 - 2	19 - 6	19 - 10	20 - 2	20 - 6	20 - 10	21 - 2	21 - 6
	24.0	13 - 10	14 - 4	14 - 11	15 - 4	15 - 10	16 - 3	16 - 8	17 - 0	17 - 5	17 - 9	18 - 1	18 - 5	18 - 9	19 - 1	19 - 4	19 - 8	19 - 11
F _b	12.0	862	932	1,000	1,066	1,129	1,191	1,251	1,310	1,368	1,424	1,480	1,534	1,587	1,640	1,692	1,742	1,793
	16.0	949	1,026	1,101	1,173	1,243	1,311	1,377	1,442	1,506	1,568	1,629	1,688	1,747	1,805	1,862	1,918	1,973
	19.2	1,008	1,090	1,170	1,246	1,321	1,393	1,464	1,533	1,600	1,666	1,731	1,794	1,857	1,918	1,978	2,038	2,097
	24.0	1,086	1,174	1,260	1,343	1,423	1,501	1,577	1,651	1,724	1,795	1,864	1,933	2,000	2,066	2,131	2,195	2,258

Note: The required bending design value, F_b, in pounds per square inch is shown at the bottom of each table and is applicable to all lumber sizes shown. Spans are shown in feet-inches and are limited to 26' and less. Check sources of supply for availability of lumber in lengths greater than 20'.

**TABLE F-6
FLOOR JOISTS WITH L/360 DEFLECTION LIMITS**

DESIGN CRITERIA:
 Deflection - For 50 psf live load.
 Limited to span in inches divided by 360.
 Strength - Live load of 50 psf plus dead load
 of 20 psf determines the required bending design value.

Joist Size (in)	Spacing (in)	Modulus of Elasticity, E, in 1,000,000 psi																
		0.8	0.9	1.0	1.1	1.2	1.3	1.4	1.5	1.6	1.7	1.8	1.9	2.0	2.1	2.2	2.3	2.4
2x 6	12.0	7 - 11	8 - 3	8 - 6	8 - 9	9 - 1	9 - 3	9 - 6	9 - 9	9 - 11	10 - 2	10 - 4	10 - 6	10 - 9	10 - 11	11 - 1	11 - 3	11 - 5
	16.0	7 - 2	7 - 6	7 - 9	8 - 0	8 - 3	8 - 5	8 - 8	8 - 10	9 - 1	9 - 3	9 - 5	9 - 7	9 - 9	9 - 11	10 - 1	10 - 2	10 - 4
	19.2	6 - 9	7 - 0	7 - 3	7 - 6	7 - 9	7 - 11	8 - 2	8 - 4	8 - 6	8 - 8	8 - 10	9 - 0	9 - 2	9 - 4	9 - 6	9 - 7	9 - 9
	24.0	6 - 3	6 - 6	6 - 9	7 - 0	7 - 2	7 - 4	7 - 7	7 - 9	7 - 11	8 - 1	8 - 3	8 - 4	8 - 6	8 - 8	8 - 9	8 - 11	9 - 1
2x 8	12.0	10 - 5	10 - 10	11 - 3	11 - 7	11 - 11	12 - 3	12 - 7	12 - 10	13 - 1	13 - 5	13 - 8	13 - 11	14 - 2	14 - 4	14 - 7	14 - 10	15 - 0
	16.0	9 - 6	9 - 10	10 - 2	10 - 6	10 - 10	11 - 1	11 - 5	11 - 8	11 - 11	12 - 2	12 - 5	12 - 7	12 - 10	13 - 1	13 - 3	13 - 5	13 - 8
	19.2	8 - 11	9 - 3	9 - 7	9 - 11	10 - 2	10 - 6	10 - 9	11 - 0	11 - 3	11 - 5	11 - 8	11 - 11	12 - 1	12 - 3	12 - 6	12 - 8	12 - 10
	24.0	8 - 3	8 - 7	8 - 11	9 - 2	9 - 6	9 - 9	10 - 0	10 - 2	10 - 5	10 - 8	10 - 10	11 - 0	11 - 3	11 - 5	11 - 7	11 - 9	11 - 11
2x10	12.0	13 - 3	13 - 10	14 - 4	14 - 9	15 - 2	15 - 7	16 - 0	16 - 5	16 - 9	17 - 1	17 - 5	17 - 9	18 - 0	18 - 4	18 - 7	18 - 11	19 - 2
	16.0	12 - 1	12 - 7	13 - 0	13 - 5	13 - 10	14 - 2	14 - 7	14 - 11	15 - 2	15 - 6	15 - 10	16 - 1	16 - 5	16 - 8	16 - 11	17 - 2	17 - 5
	19.2	11 - 4	11 - 10	12 - 3	12 - 8	13 - 0	13 - 4	13 - 8	14 - 0	14 - 4	14 - 7	14 - 11	15 - 2	15 - 5	15 - 8	15 - 11	16 - 2	16 - 5
	24.0	10 - 7	11 - 0	11 - 4	11 - 9	12 - 1	12 - 5	12 - 8	13 - 0	13 - 3	13 - 7	13 - 10	14 - 1	14 - 4	14 - 7	14 - 9	15 - 0	15 - 2
2x12	12.0	16 - 2	16 - 10	17 - 5	18 - 0	18 - 6	19 - 0	19 - 6	19 - 11	20 - 4	20 - 9	21 - 2	21 - 7	21 - 11	22 - 3	22 - 8	23 - 0	23 - 4
	16.0	14 - 8	15 - 3	15 - 10	16 - 4	16 - 10	17 - 3	17 - 8	18 - 1	18 - 6	18 - 10	19 - 3	19 - 7	19 - 11	20 - 3	20 - 7	20 - 11	21 - 2
	19.2	13 - 10	14 - 4	14 - 11	15 - 4	15 - 10	16 - 3	16 - 8	17 - 0	17 - 5	17 - 9	18 - 1	18 - 5	18 - 9	19 - 1	19 - 4	19 - 8	19 - 11
	24.0	12 - 10	13 - 4	13 - 10	14 - 3	14 - 8	15 - 1	15 - 5	15 - 10	16 - 2	16 - 6	16 - 10	17 - 1	17 - 5	17 - 8	18 - 0	18 - 3	18 - 6
F _b	12.0	866	937	1,005	1,071	1,135	1,198	1,258	1,317	1,375	1,432	1,488	1,542	1,596	1,649	1,701	1,752	1,802
	16.0	954	1,032	1,107	1,179	1,250	1,318	1,385	1,450	1,514	1,576	1,637	1,698	1,757	1,815	1,872	1,928	1,984
	19.2	1,013	1,096	1,176	1,253	1,328	1,401	1,472	1,541	1,609	1,675	1,740	1,804	1,867	1,928	1,989	2,049	2,108
	24.0	1,092	1,181	1,267	1,350	1,430	1,509	1,585	1,660	1,733	1,804	1,874	1,943	2,011	2,077	2,143	2,207	2,271

Note: The required bending design value, F_b, in pounds per square inch is shown at the bottom of each table and is applicable to all lumber sizes shown. Spans are shown in feet-inches and are limited to 26' and less. Check sources of supply for availability of lumber in lengths greater than 20'.

TABLE F-7
FLOOR JOISTS WITH L/360 DEFLECTION LIMITS

DESIGN CRITERIA:
Deflection - For 60 psf live load.
Limited to span in inches divided by 360.
Strength - Live load of 60 psf plus dead load
of 20 psf determines the required bending design value.

Joist Size (in)	Spacing (in)	Modulus of Elasticity, E, in 1,000,000 psi																
		0.8	0.9	1.0	1.1	1.2	1.3	1.4	1.5	1.6	1.7	1.8	1.9	2.0	2.1	2.2	2.3	2.4
2x 6	12.0	7 - 5	7 - 9	8 - 0	8 - 3	8 - 6	8 - 9	8 - 11	9 - 2	9 - 4	9 - 7	9 - 9	9 - 11	10 - 1	10 - 3	10 - 5	10 - 7	10 - 9
	16.0	6 - 9	7 - 0	7 - 3	7 - 6	7 - 9	7 - 11	8 - 2	8 - 4	8 - 6	8 - 8	8 - 10	9 - 0	9 - 2	9 - 4	9 - 6	9 - 7	9 - 9
	19.2	6 - 4	6 - 7	6 - 10	7 - 1	7 - 3	7 - 6	7 - 8	7 - 10	8 - 0	8 - 2	8 - 4	8 - 6	8 - 8	8 - 9	8 - 11	9 - 0	9 - 2
	24.0	5 - 11	6 - 2	6 - 4	6 - 7	6 - 9	6 - 11	7 - 1	7 - 3	7 - 5	7 - 7	7 - 9	7 - 10	8 - 0	8 - 2	8 - 3	8 - 5	8 - 6
2x 8	12.0	9 - 10	10 - 2	10 - 7	10 - 11	11 - 3	11 - 6	11 - 10	12 - 1	12 - 4	12 - 7	12 - 10	13 - 1	13 - 4	13 - 6	13 - 9	13 - 11	14 - 2
	16.0	8 - 11	9 - 3	9 - 7	9 - 11	10 - 2	10 - 6	10 - 9	11 - 0	11 - 3	11 - 5	11 - 8	11 - 11	12 - 1	12 - 3	12 - 6	12 - 8	12 - 10
	19.2	8 - 5	8 - 9	9 - 0	9 - 4	9 - 7	9 - 10	10 - 1	10 - 4	10 - 7	10 - 9	11 - 0	11 - 2	11 - 4	11 - 7	11 - 9	11 - 11	12 - 1
	24.0	7 - 9	8 - 1	8 - 5	8 - 8	8 - 11	9 - 2	9 - 4	9 - 7	9 - 10	10 - 0	10 - 2	10 - 5	10 - 7	10 - 9	10 - 11	11 - 1	11 - 3
2x10	12.0	12 - 6	13 - 0	13 - 6	13 - 11	14 - 4	14 - 8	15 - 1	15 - 5	15 - 9	16 - 1	16 - 5	16 - 8	17 - 0	17 - 3	17 - 6	17 - 9	18 - 0
	16.0	11 - 4	11 - 10	12 - 3	12 - 8	13 - 0	13 - 4	13 - 8	14 - 0	14 - 4	14 - 7	14 - 11	15 - 2	15 - 5	15 - 8	15 - 11	16 - 2	16 - 5
	19.2	10 - 8	11 - 1	11 - 6	11 - 11	12 - 3	12 - 7	12 - 11	13 - 2	13 - 6	13 - 9	14 - 0	14 - 3	14 - 6	14 - 9	15 - 0	15 - 2	15 - 5
	24.0	9 - 11	10 - 4	10 - 8	11 - 0	11 - 4	11 - 8	11 - 11	12 - 3	12 - 6	12 - 9	13 - 0	13 - 3	13 - 6	13 - 8	13 - 11	14 - 1	14 - 4
2x12	12.0	15 - 2	15 - 10	16 - 5	16 - 11	17 - 5	17 - 11	18 - 4	18 - 9	19 - 2	19 - 7	19 - 11	20 - 3	20 - 8	21 - 0	21 - 4	21 - 7	21 - 11
	16.0	13 - 10	14 - 4	14 - 11	15 - 4	15 - 10	16 - 3	16 - 8	17 - 0	17 - 5	17 - 9	18 - 1	18 - 5	18 - 9	19 - 1	19 - 4	19 - 8	19 - 11
	19.2	13 - 0	13 - 6	14 - 0	14 - 5	14 - 11	15 - 3	15 - 8	16 - 0	16 - 5	16 - 9	17 - 0	17 - 4	17 - 8	17 - 11	18 - 3	18 - 6	18 - 9
	24.0	12 - 1	12 - 7	13 - 0	13 - 5	13 - 10	14 - 2	14 - 7	14 - 11	15 - 2	15 - 6	15 - 10	16 - 1	16 - 5	16 - 8	16 - 11	17 - 2	17 - 5
F _b	12.0	877	949	1,018	1,084	1,149	1,212	1,273	1,333	1,392	1,449	1,506	1,561	1,615	1,669	1,721	1,773	1,824
	16.0	965	1,044	1,120	1,193	1,265	1,334	1,402	1,468	1,532	1,595	1,657	1,718	1,778	1,837	1,894	1,951	2,008
	19.2	1,026	1,109	1,190	1,268	1,344	1,418	1,489	1,559	1,628	1,695	1,761	1,826	1,889	1,952	2,013	2,074	2,133
	24.0	1,105	1,195	1,282	1,366	1,448	1,527	1,604	1,680	1,754	1,826	1,897	1,967	2,035	2,102	2,169	2,234	2,298

Note: The required bending design value, F_b, in pounds per square inch is shown at the bottom of each table and is applicable to all lumber sizes shown. Spans are shown in feet-inches and are limited to 26' and less. Check sources of supply for availability of lumber in lengths greater than 20'.

**TABLE C-1
CEILING JOISTS WITH L/240 DEFLECTION LIMITS**

DESIGN CRITERIA:
 Deflection - For 10 psf live load.
 Limited to span in inches divided by 240.
 Strength - Live load of 10 psf plus dead load
 of 5 psf determines the required bending design value.

Joist Size (in)	Spacing (in)	Modulus of Elasticity, E, in 1,000,000 psi																
		0.8	0.9	1.0	1.1	1.2	1.3	1.4	1.5	1.6	1.7	1.8	1.9	2.0	2.1	2.2	2.3	2.4
2x 4	12.0	9 - 10	10 - 3	10 - 7	10 - 11	11 - 3	11 - 7	11 - 10	12 - 2	12 - 5	12 - 8	12 - 11	13 - 2	13 - 4	13 - 7	13 - 9	14 - 0	14 - 2
	16.0	8 - 11	9 - 4	9 - 8	9 - 11	10 - 3	10 - 6	10 - 9	11 - 0	11 - 3	11 - 6	11 - 9	11 - 11	12 - 2	12 - 4	12 - 6	12 - 9	12 - 11
	19.2	8 - 5	8 - 9	9 - 1	9 - 4	9 - 8	9 - 11	10 - 2	10 - 4	10 - 7	10 - 10	11 - 0	11 - 3	11 - 5	11 - 7	11 - 9	12 - 0	12 - 2
	24.0	7 - 10	8 - 1	8 - 5	8 - 8	8 - 11	9 - 2	9 - 5	9 - 8	9 - 10	10 - 0	10 - 3	10 - 5	10 - 7	10 - 9	10 - 11	11 - 1	11 - 3
2x 6	12.0	15 - 6	16 - 1	16 - 8	17 - 2	17 - 8	18 - 2	18 - 8	19 - 1	19 - 6	19 - 11	20 - 3	20 - 8	21 - 0	21 - 4	21 - 8	22 - 0	22 - 4
	16.0	14 - 1	14 - 7	15 - 2	15 - 7	16 - 1	16 - 6	16 - 11	17 - 4	17 - 8	18 - 1	18 - 5	18 - 9	19 - 1	19 - 5	19 - 8	20 - 0	20 - 3
	19.2	13 - 3	13 - 9	14 - 3	14 - 8	15 - 2	15 - 7	15 - 11	16 - 4	16 - 8	17 - 0	17 - 4	17 - 8	17 - 11	18 - 3	18 - 6	18 - 10	19 - 1
	24.0	12 - 3	12 - 9	13 - 3	13 - 8	14 - 1	14 - 5	14 - 9	15 - 2	15 - 6	15 - 9	16 - 1	16 - 4	16 - 8	16 - 11	17 - 2	17 - 5	17 - 8
2x 8	12.0	20 - 5	21 - 2	21 - 11	22 - 8	23 - 4	24 - 0	24 - 7	25 - 2	25 - 8	-	-	-	-	-	-	-	-
	16.0	18 - 6	19 - 3	19 - 11	20 - 7	21 - 2	21 - 9	22 - 4	22 - 10	23 - 4	23 - 10	24 - 3	24 - 8	25 - 2	25 - 7	25 - 11	-	-
	19.2	17 - 5	18 - 2	18 - 9	19 - 5	19 - 11	20 - 6	21 - 0	21 - 6	21 - 11	22 - 5	22 - 10	23 - 3	23 - 8	24 - 0	24 - 5	24 - 9	25 - 2
	24.0	16 - 2	16 - 10	17 - 5	18 - 0	18 - 6	19 - 0	19 - 6	19 - 11	20 - 5	20 - 10	21 - 2	21 - 7	21 - 11	22 - 4	22 - 8	23 - 0	23 - 4
2x10	12.0	26 - 0	-	-	-	-	-	-	-	-	-	-	-	-	-	-	-	-
	16.0	23 - 8	24 - 7	25 - 5	-	-	-	-	-	-	-	-	-	-	-	-	-	-
	19.2	22 - 3	23 - 2	23 - 11	24 - 9	25 - 5	-	-	-	-	-	-	-	-	-	-	-	-
	24.0	20 - 8	21 - 6	22 - 3	22 - 11	23 - 8	24 - 3	24 - 10	25 - 5	26 - 0	-	-	-	-	-	-	-	-
F _b	12.0	711	769	825	880	932	983	1,033	1,082	1,129	1,176	1,221	1,266	1,310	1,354	1,396	1,438	1,480
	16.0	783	847	909	968	1,026	1,082	1,137	1,191	1,243	1,294	1,344	1,394	1,442	1,490	1,537	1,583	1,629
	19.2	832	900	965	1,029	1,090	1,150	1,208	1,265	1,321	1,375	1,429	1,481	1,533	1,583	1,633	1,682	1,731
	24.0	896	969	1,040	1,108	1,174	1,239	1,302	1,363	1,423	1,481	1,539	1,595	1,651	1,706	1,759	1,812	1,864

Note: The required bending design value, F_b, in pounds per square inch is shown at the bottom of each table and is applicable to all lumber sizes shown. Spans are shown in feet-inches and are limited to 26' and less. Check sources of supply for availability of lumber in lengths greater than 20'.

TABLE C-2
CEILING JOISTS WITH L/240 DEFLECTION LIMITS

DESIGN CRITERIA:
Deflection - For 20 psf live load.
Limited to span in inches divided by 240.
Strength - Live load of 20 psf plus dead load
of 10 psf determines the required bending design value.

Joist Size (in)	Spacing (in)	Modulus of Elasticity, E, in 1,000,000 psi																
		0.8	0.9	1.0	1.1	1.2	1.3	1.4	1.5	1.6	1.7	1.8	1.9	2.0	2.1	2.2	2.3	2.4
2x 4	12.0	7 - 10	8 - 1	8 - 5	8 - 8	8 - 11	9 - 2	9 - 5	9 - 8	9 - 10	10 - 0	10 - 3	10 - 5	10 - 7	10 - 9	10 - 11	11 - 1	11 - 3
	16.0	7 - 1	7 - 5	7 - 8	7 - 11	8 - 1	8 - 4	8 - 7	8 - 9	8 - 11	9 - 1	9 - 4	9 - 6	9 - 8	9 - 9	9 - 11	10 - 1	10 - 3
	19.2	6 - 8	6 - 11	7 - 2	7 - 5	7 - 8	7 - 10	8 - 1	8 - 3	8 - 5	8 - 7	8 - 9	8 - 11	9 - 1	9 - 3	9 - 4	9 - 6	9 - 8
	24.0	6 - 2	6 - 5	6 - 8	6 - 11	7 - 1	7 - 3	7 - 6	7 - 8	7 - 10	8 - 0	8 - 1	8 - 3	8 - 5	8 - 7	8 - 8	8 - 10	8 - 11
2x 6	12.0	12 - 3	12 - 9	13 - 3	13 - 8	14 - 1	14 - 5	14 - 9	15 - 2	15 - 6	15 - 9	16 - 1	16 - 4	16 - 8	16 - 11	17 - 2	17 - 5	17 - 8
	16.0	11 - 2	11 - 7	12 - 0	12 - 5	12 - 9	13 - 1	13 - 5	13 - 9	14 - 1	14 - 4	14 - 7	14 - 11	15 - 2	15 - 5	15 - 7	15 - 10	16 - 1
	19.2	10 - 6	10 - 11	11 - 4	11 - 8	12 - 0	12 - 4	12 - 8	12 - 11	13 - 3	13 - 6	13 - 9	14 - 0	14 - 3	14 - 6	14 - 8	14 - 11	15 - 2
	24.0	9 - 9	10 - 2	10 - 6	10 - 10	11 - 2	11 - 5	11 - 9	12 - 0	12 - 3	12 - 6	12 - 9	13 - 0	13 - 3	13 - 5	13 - 8	13 - 10	14 - 1
2x 8	12.0	16 - 2	16 - 10	17 - 5	18 - 0	18 - 6	19 - 0	19 - 6	19 - 11	20 - 5	20 - 10	21 - 2	21 - 7	21 - 11	22 - 4	22 - 8	23 - 0	23 - 4
	16.0	14 - 8	15 - 3	15 - 10	16 - 4	16 - 10	17 - 3	17 - 9	18 - 2	18 - 6	18 - 11	19 - 3	19 - 7	19 - 11	20 - 3	20 - 7	20 - 11	21 - 2
	19.2	13 - 10	14 - 5	14 - 11	15 - 5	15 - 10	16 - 3	16 - 8	17 - 1	17 - 5	17 - 9	18 - 2	18 - 5	18 - 9	19 - 1	19 - 5	19 - 8	19 - 11
	24.0	12 - 10	13 - 4	13 - 10	14 - 3	14 - 8	15 - 1	15 - 6	15 - 10	16 - 2	16 - 6	16 - 10	17 - 2	17 - 5	17 - 9	18 - 0	18 - 3	18 - 6
2x10	12.0	20 - 8	21 - 6	22 - 3	22 - 11	23 - 8	24 - 3	24 - 10	25 - 5	26 - 0	-	-	-	-	-	-	-	-
	16.0	18 - 9	19 - 6	20 - 2	20 - 10	21 - 6	22 - 1	22 - 7	23 - 2	23 - 8	24 - 1	24 - 7	25 - 0	25 - 5	25 - 10	-	-	-
	19.2	17 - 8	18 - 4	19 - 0	19 - 7	20 - 2	20 - 9	21 - 3	21 - 9	22 - 3	22 - 8	23 - 2	23 - 7	23 - 11	24 - 4	24 - 9	25 - 1	25 - 5
	24.0	16 - 5	17 - 0	17 - 8	18 - 3	18 - 9	19 - 3	19 - 9	20 - 2	20 - 8	21 - 1	21 - 6	21 - 10	22 - 3	22 - 7	22 - 11	23 - 4	23 - 8
F _b	12.0	896	969	1,040	1,108	1,174	1,239	1,302	1,363	1,423	1,481	1,539	1,595	1,651	1,706	1,759	1,812	1,864
	16.0	986	1,067	1,145	1,220	1,293	1,364	1,433	1,500	1,566	1,631	1,694	1,756	1,817	1,877	1,936	1,995	2,052
	19.2	1,048	1,134	1,216	1,296	1,374	1,449	1,522	1,594	1,664	1,733	1,800	1,866	1,931	1,995	2,058	2,120	2,181
	24.0	1,129	1,221	1,310	1,396	1,480	1,561	1,640	1,717	1,793	1,866	1,939	2,010	2,080	2,149	2,217	2,283	2,349

Note: The required bending design value, F_b, in pounds per square inch is shown at the bottom of each table and is applicable to all lumber sizes shown. Spans are shown in feet-inches and are limited to 26' and less. Check sources of supply for availability of lumber in lengths greater than 20'.

**TABLE R-1
RAFTERS WITH L/240 DEFLECTION LIMITATION**

DESIGN CRITERIA:

Strength - Live load of 20 psf plus

Dead Load of 10 psf determines the required bending design value.

Deflection - For 20 psf live load.

Limited to span in inches divided by 240.

Rafter Size (in)	Spacing (in)	Bending Design Value, F_b , (psi)																					
		300	400	500	600	700	800	900	1000	1100	1200	1300	1400	1500	1600	1700	1800	1900	2000	2100	2200	2300	2400
2x 6	12.0	7-1	8-2	9-2	10-0	10-10	11-7	12-4	13-0	13-7	14-2	14-9	15-4	15-11	16-5	16-11	17-5	17-10	-	-	-	-	-
	16.0	6-2	7-1	7-11	8-8	9-5	10-0	10-8	11-3	11-9	12-4	12-10	13-3	13-9	14-2	14-8	15-1	15-6	15-11	16-3	-	-	-
	19.2	5-7	6-6	7-3	7-11	8-7	9-2	9-9	10-3	10-9	11-3	11-8	12-2	12-7	13-0	13-4	13-9	14-2	14-6	14-10	15-2	15-7	-
	24.0	5-0	5-10	6-6	7-1	7-8	8-2	8-8	9-2	9-7	10-0	10-5	10-10	11-3	11-7	11-11	12-4	12-8	13-0	13-3	13-7	13-11	14-2
2x 8	12.0	9-4	10-10	12-1	13-3	14-4	15-3	16-3	17-1	17-11	18-9	19-6	20-3	20-11	21-7	22-3	22-11	23-7	-	-	-	-	-
	16.0	8-1	9-4	10-6	11-6	12-5	13-3	14-0	14-10	15-6	16-3	16-10	17-6	18-2	18-9	19-4	19-10	20-5	20-11	21-5	-	-	-
	19.2	7-5	8-7	9-7	10-6	11-4	12-1	12-10	13-6	14-2	14-10	15-5	16-0	16-7	17-1	17-7	18-2	18-7	19-1	19-7	20-0	20-6	-
	24.0	6-7	7-8	8-7	9-4	10-1	10-10	11-6	12-1	12-8	13-3	13-9	14-4	14-10	15-3	15-9	16-3	16-8	17-1	17-6	17-11	18-4	18-9
2x10	12.0	11-11	13-9	15-5	16-11	18-3	19-6	20-8	21-10	22-10	23-11	24-10	25-10	-	-	-	-	-	-	-	-	-	-
	16.0	10-4	11-11	13-4	14-8	15-10	16-11	17-11	18-11	19-10	20-8	21-6	22-4	23-2	23-11	24-7	25-4	26-0	-	-	-	-	-
	19.2	9-5	10-11	12-2	13-4	14-5	15-5	16-4	17-3	18-1	18-11	19-8	20-5	21-1	21-10	22-6	23-2	23-9	24-5	25-0	25-7	-	-
	24.0	8-5	9-9	10-11	11-11	12-11	13-9	14-8	15-5	16-2	16-11	17-7	18-3	18-11	19-6	20-1	20-8	21-3	21-10	22-4	22-10	23-5	23-11
2x12	12.0	14-6	16-9	18-9	20-6	22-2	23-9	25-2	-	-	-	-	-	-	-	-	-	-	-	-	-	-	-
	16.0	12-7	14-6	16-3	17-9	19-3	20-6	21-9	23-0	24-1	25-2	-	-	-	-	-	-	-	-	-	-	-	-
	19.2	11-6	13-3	14-10	16-3	17-6	18-9	19-11	21-0	22-0	23-0	23-11	24-10	25-8	-	-	-	-	-	-	-	-	-
	24.0	10-3	11-10	13-3	14-6	15-8	16-9	17-9	18-9	19-8	20-6	21-5	22-2	23-0	23-9	24-5	25-2	25-10	-	-	-	-	-
E	12.0	0.15	0.24	0.33	0.44	0.55	0.67	0.80	0.94	1.09	1.24	1.40	1.56	1.73	1.91	2.09	2.28	2.47	-	-	-	-	-
	16.0	0.13	0.21	0.29	0.38	0.48	0.58	0.70	0.82	0.94	1.07	1.21	1.35	1.50	1.65	1.81	1.97	2.14	2.31	2.48	-	-	-
	19.2	0.12	0.19	0.26	0.35	0.44	0.53	0.64	0.75	0.86	0.98	1.10	1.23	1.37	1.51	1.65	1.80	1.95	2.11	2.27	2.43	2.60	-
	24.0	0.11	0.17	0.24	0.31	0.39	0.48	0.57	0.67	0.77	0.88	0.99	1.10	1.22	1.35	1.48	1.61	1.75	1.89	2.03	2.18	2.33	2.48

Note: The required modulus of elasticity, E, in 1,000,000 pounds per square inch is shown at the bottom of each table, is limited to 2.6 million psi and less, and is applicable to all lumber sizes shown. Spans are shown in feet-inches and are limited to 26' and less. Check sources of supply for availability of lumber in lengths greater than 20'.

TABLE R-2
RAFTERS WITH L/240 DEFLECTION LIMITATION

DESIGN CRITERIA:
Strength - Live load of 30 psf plus
Dead Load of 10 psf determines the required bending design value.
Deflection - For 30 psf live load.
Limited to span in inches divided by 240.

Rafter Size (in)	Spacing (in)	Bending Design Value, F _b , (psi)																					
		300	400	500	600	700	800	900	1000	1100	1200	1300	1400	1500	1600	1700	1800	1900	2000	2100	2200	2300	2400
2x 6	12.0	6-2	7-1	7-11	8-8	9-5	10-0	10-8	11-3	11-9	12-4	12-10	13-3	13-9	14-2	14-8	15-1	15-6	15-11	-	-	-	-
	16.0	5-4	6-2	6-11	7-6	8-2	8-8	9-3	9-9	10-2	10-8	11-1	11-6	11-11	12-4	12-8	13-1	13-5	13-9	14-1	14-5	-	-
	19.2	4-10	5-7	6-3	6-11	7-5	7-11	8-5	8-11	9-4	9-9	10-1	10-6	10-10	11-3	11-7	11-11	12-3	12-7	12-10	13-2	13-6	-
	24.0	4-4	5-0	5-7	6-2	6-8	7-1	7-6	7-11	8-4	8-8	9-1	9-5	9-9	10-0	10-4	10-8	10-11	11-3	11-6	11-9	12-0	12-4
2x 8	12.0	8-1	9-4	10-6	11-6	12-5	13-3	14-0	14-10	15-6	16-3	16-10	17-6	18-2	18-9	19-4	19-10	20-5	20-11	-	-	-	-
	16.0	7-0	8-1	9-1	9-11	10-9	11-6	12-2	12-10	13-5	14-0	14-7	15-2	15-8	16-3	16-9	17-2	17-8	18-2	18-7	19-0	-	-
	19.2	6-5	7-5	8-3	9-1	9-9	10-6	11-1	11-8	12-3	12-10	13-4	13-10	14-4	14-10	15-3	15-8	16-2	16-7	16-11	17-4	17-9	-
	24.0	5-9	6-7	7-5	8-1	8-9	9-4	9-11	10-6	11-0	11-6	11-11	12-5	12-10	13-3	13-8	14-0	14-5	14-10	15-2	15-6	15-10	16-3
2x10	12.0	10-4	11-11	13-4	14-8	15-10	16-11	17-11	18-11	19-10	20-8	21-6	22-4	23-2	23-11	24-7	25-4	26-0	-	-	-	-	-
	16.0	8-11	10-4	11-7	12-8	13-8	14-8	15-6	16-4	17-2	17-11	18-8	19-4	20-0	20-8	21-4	21-11	22-6	23-2	23-8	24-3	-	-
	19.2	8-2	9-5	10-7	11-7	12-6	13-4	14-2	14-11	15-8	16-4	17-0	17-8	18-3	18-11	19-6	20-0	20-7	21-1	21-8	22-2	22-8	-
	24.0	7-4	8-5	9-5	10-4	11-2	11-11	12-8	13-4	14-0	14-8	15-3	15-10	16-4	16-11	17-5	17-11	18-5	18-11	19-4	19-10	20-3	20-8
2x12	12.0	12-7	14-6	16-3	17-9	19-3	20-6	21-9	23-0	24-1	25-2	-	-	-	-	-	-	-	-	-	-	-	-
	16.0	10-11	12-7	14-1	15-5	16-8	17-9	18-10	19-11	20-10	21-9	22-8	23-6	24-4	25-2	25-11	-	-	-	-	-	-	-
	19.2	9-11	11-6	12-10	14-1	15-2	16-3	17-3	18-2	19-0	19-11	20-8	21-6	22-3	23-0	23-8	24-4	25-0	25-8	-	-	-	-
	24.0	8-11	10-3	11-6	12-7	13-7	14-6	15-5	16-3	17-0	17-9	18-6	19-3	19-11	20-6	21-2	21-9	22-5	23-0	23-6	24-1	24-8	25-2
E	12.0	0.15	0.23	0.32	0.43	0.54	0.66	0.78	0.92	1.06	1.21	1.36	1.52	1.69	1.86	2.04	2.22	2.41	2.60	-	-	-	-
	16.0	0.13	0.20	0.28	0.37	0.47	0.57	0.68	0.80	0.92	1.05	1.18	1.32	1.46	1.61	1.76	1.92	2.08	2.25	2.42	2.60	-	-
	19.2	0.12	0.18	0.26	0.34	0.43	0.52	0.62	0.73	0.84	0.95	1.08	1.20	1.33	1.47	1.61	1.75	1.90	2.05	2.21	2.37	2.53	-
	24.0	0.11	0.16	0.23	0.30	0.38	0.46	0.55	0.65	0.75	0.85	0.96	1.08	1.19	1.31	1.44	1.57	1.70	1.84	1.98	2.12	2.27	2.41

Note: The required modulus of elasticity, E, in 1,000,000 pounds per square inch is shown at the bottom of each table, is limited to 2.6 million psi and less, and is applicable to all lumber sizes shown. Spans are shown in feet-inches and are limited to 26' and less. Check sources of supply for availability of lumber in lengths greater than 20'.

**TABLE R-3
RAFTERS WITH L/240 DEFLECTION LIMITATION**

DESIGN CRITERIA:

Strength - Live load of 40 psf plus

Dead Load of 10 psf determines the required bending design value.

Deflection - For 40 psf live load.

Limited to span in inches divided by 240.

Rafter Size (in)	Spacing (in)	Bending Design Value, F_b , (psi)																					
		300	400	500	600	700	800	900	1000	1100	1200	1300	1400	1500	1600	1700	1800	1900	2000	2100	2200	2300	2400
2x 6	12.0	5-6	6-4	7-1	7-9	8-5	9-0	9-6	10-0	10-6	11-0	11-5	11-11	12-4	12-8	13-1	13-6	13-10	14-2	-	-	-	-
	16.0	4-9	5-6	6-2	6-9	7-3	7-9	8-3	8-8	9-1	9-6	9-11	10-3	10-8	11-0	11-4	11-8	12-0	12-4	12-7	12-11	-	-
	19.2	4-4	5-0	5-7	6-2	6-8	7-1	7-6	7-11	8-4	8-8	9-1	9-5	9-9	10-0	10-4	10-8	10-11	11-3	11-6	11-9	12-0	12-4
	24.0	3-11	4-6	5-0	5-6	5-11	6-4	6-9	7-1	7-5	7-9	8-1	8-5	8-8	9-0	9-3	9-6	9-9	10-0	10-3	10-6	10-9	11-0
2x 8	12.0	7-3	8-4	9-4	10-3	11-1	11-10	12-7	13-3	13-11	14-6	15-1	15-8	16-3	16-9	17-3	17-9	18-3	18-9	-	-	-	-
	16.0	6-3	7-3	8-1	8-11	9-7	10-3	10-11	11-6	12-0	12-7	13-1	13-7	14-0	14-6	14-11	15-5	15-10	16-3	16-7	17-0	-	-
	19.2	5-9	6-7	7-5	8-1	8-9	9-4	9-11	10-6	11-0	11-6	11-11	12-5	12-10	13-3	13-8	14-0	14-5	14-10	15-2	15-6	15-10	16-3
	24.0	5-2	5-11	6-7	7-3	7-10	8-4	8-11	9-4	9-10	10-3	10-8	11-1	11-6	11-10	12-2	12-7	12-11	13-3	13-7	13-11	14-2	14-6
2x10	12.0	9-3	10-8	11-11	13-1	14-2	15-1	16-0	16-11	17-9	18-6	19-3	20-0	20-8	21-4	22-0	22-8	23-3	23-11	-	-	-	-
	16.0	8-0	9-3	10-4	11-4	12-3	13-1	13-11	14-8	15-4	16-0	16-8	17-4	17-11	18-6	19-1	19-7	20-2	20-8	21-2	21-8	-	-
	19.2	7-4	8-5	9-5	10-4	11-2	11-11	12-8	13-4	14-0	14-8	15-3	15-10	16-4	16-11	17-5	17-11	18-5	18-11	19-4	19-10	20-3	20-8
	24.0	6-6	7-7	8-5	9-3	10-0	10-8	11-4	11-11	12-6	13-1	13-7	14-2	14-8	15-1	15-7	16-0	16-6	16-11	17-4	17-9	18-1	18-6
2x12	12.0	11-3	13-0	14-6	15-11	17-2	18-4	19-6	20-6	21-7	22-6	23-5	24-4	25-2	26-0	-	-	-	-	-	-	-	-
	16.0	9-9	11-3	12-7	13-9	14-11	15-11	16-11	17-9	18-8	19-6	20-3	21-1	21-9	22-6	23-2	23-10	24-6	25-2	25-9	-	-	-
	19.2	8-11	10-3	11-6	12-7	13-7	14-6	15-5	16-3	17-0	17-9	18-6	19-3	19-11	20-6	21-2	21-9	22-5	23-0	23-6	24-1	24-8	25-2
	24.0	7-11	9-2	10-3	11-3	12-2	13-0	13-9	14-6	15-3	15-11	16-7	17-2	17-9	18-4	18-11	19-6	20-0	20-6	21-1	21-7	22-0	22-6
E	12.0	0.14	0.22	0.31	0.41	0.51	0.63	0.75	0.88	1.01	1.15	1.30	1.45	1.61	1.77	1.94	2.12	2.30	2.48	-	-	-	-
	16.0	0.12	0.19	0.27	0.35	0.44	0.54	0.65	0.76	0.88	1.00	1.12	1.26	1.39	1.54	1.68	1.83	1.99	2.15	2.31	2.48	-	-
	19.2	0.11	0.18	0.24	0.32	0.41	0.50	0.59	0.69	0.80	0.91	1.03	1.15	1.27	1.40	1.54	1.67	1.81	1.96	2.11	2.26	2.42	2.58
	24.0	0.10	0.16	0.22	0.29	0.36	0.44	0.53	0.62	0.71	0.81	0.92	1.03	1.14	1.25	1.37	1.50	1.62	1.75	1.89	2.02	2.16	2.30

Note: The required modulus of elasticity, E, in 1,000,000 pounds per square inch is shown at the bottom of each table, is limited to 2.6 million psi and less, and is applicable to all lumber sizes shown. Spans are shown in feet-inches and are limited to 26' and less. Check sources of supply for availability of lumber in lengths greater than 20'.

TABLE R-4
RAFTERS WITH L/240 DEFLECTION LIMITATION

DESIGN CRITERIA:
Strength - Live load of 50 psf plus
Dead Load of 10 psf determines the required bending design value.
Deflection - For 50 psf live load.
Limited to span in inches divided by 240.

Rafter Size (in)	Spacing (in)	Bending Design Value, F _b , (psi)																					
		300	400	500	600	700	800	900	1000	1100	1200	1300	1400	1500	1600	1700	1800	1900	2000	2100	2200	2300	2400
2x 6	12.0	5-0	5-10	6-6	7-1	7-8	8-2	8-8	9-2	9-7	10-0	10-5	10-10	11-3	11-7	11-11	12-4	12-8	13-0	13-3	-	-	-
	16.0	4-4	5-0	5-7	6-2	6-8	7-1	7-6	7-11	8-4	8-8	9-1	9-5	9-9	10-0	10-4	10-8	10-11	11-3	11-6	11-9	12-0	-
	19.2	4-0	4-7	5-1	5-7	6-1	6-6	6-11	7-3	7-7	7-11	8-3	8-7	8-11	9-2	9-5	9-9	10-0	10-3	10-6	10-9	11-0	11-3
	24.0	3-7	4-1	4-7	5-0	5-5	5-10	6-2	6-6	6-10	7-1	7-5	7-8	7-11	8-2	8-5	8-8	8-11	9-2	9-5	9-7	9-10	10-0
2x 8	12.0	6-7	7-8	8-7	9-4	10-1	10-10	11-6	12-1	12-8	13-3	13-9	14-4	14-10	15-3	15-9	16-3	16-8	17-1	17-6	-	-	-
	16.0	5-9	6-7	7-5	8-1	8-9	9-4	9-11	10-6	11-0	11-6	11-11	12-5	12-10	13-3	13-8	14-0	14-5	14-10	15-2	15-6	15-10	-
	19.2	5-3	6-1	6-9	7-5	8-0	8-7	9-1	9-7	10-0	10-6	10-11	11-4	11-8	12-1	12-5	12-10	13-2	13-6	13-10	14-2	14-6	14-10
	24.0	4-8	5-5	6-1	6-7	7-2	7-8	8-1	8-7	9-0	9-4	9-9	10-1	10-6	10-10	11-2	11-6	11-9	12-1	12-5	12-8	12-11	13-3
2x10	12.0	8-5	9-9	10-11	11-11	12-11	13-9	14-8	15-5	16-2	16-11	17-7	18-3	18-11	19-6	20-1	20-8	21-3	21-10	22-4	-	-	-
	16.0	7-4	8-5	9-5	10-4	11-2	11-11	12-8	13-4	14-0	14-8	15-3	15-10	16-4	16-11	17-5	17-11	18-5	18-11	19-4	19-10	20-3	-
	19.2	6-8	7-9	8-7	9-5	10-2	10-11	11-7	12-2	12-9	13-4	13-11	14-5	14-11	15-5	15-11	16-4	16-10	17-3	17-8	18-1	18-6	18-11
	24.0	6-0	6-11	7-9	8-5	9-1	9-9	10-4	10-11	11-5	11-11	12-5	12-11	13-4	13-9	14-3	14-8	15-0	15-5	15-10	16-2	16-6	16-11
2x12	12.0	10-3	11-10	13-3	14-6	15-8	16-9	17-9	18-9	19-8	20-6	21-5	22-2	23-0	23-9	24-5	25-2	25-10	-	-	-	-	-
	16.0	8-11	10-3	11-6	12-7	13-7	14-6	15-5	16-3	17-0	17-9	18-6	19-3	19-11	20-6	21-2	21-9	22-5	23-0	23-6	24-1	24-8	-
	19.2	8-1	9-5	10-6	11-6	12-5	13-3	14-1	14-10	15-7	16-3	16-11	17-6	18-2	18-9	19-4	19-11	20-5	21-0	21-6	22-0	22-6	23-0
	24.0	7-3	8-5	9-5	10-3	11-1	11-10	12-7	13-3	13-11	14-6	15-1	15-8	16-3	16-9	17-3	17-9	18-3	18-9	19-3	19-8	20-1	20-6
E	12.0	0.14	0.21	0.29	0.39	0.49	0.60	0.71	0.83	0.96	1.10	1.24	1.38	1.53	1.69	1.85	2.01	2.18	2.36	2.54	-	-	-
	16.0	0.12	0.18	0.26	0.34	0.42	0.52	0.62	0.72	0.83	0.95	1.07	1.20	1.33	1.46	1.60	1.74	1.89	2.04	2.20	2.35	2.52	-
	19.2	0.11	0.17	0.23	0.31	0.39	0.47	0.56	0.66	0.76	0.87	0.98	1.09	1.21	1.33	1.46	1.59	1.73	1.86	2.00	2.15	2.30	2.45
	24.0	0.10	0.15	0.21	0.27	0.35	0.42	0.50	0.59	0.68	0.77	0.87	0.98	1.08	1.19	1.31	1.42	1.54	1.67	1.79	1.92	2.06	2.19

Note: The required modulus of elasticity, E, in 1,000,000 pounds per square inch is shown at the bottom of each table, is limited to 2.6 million psi and less, and is applicable to all lumber sizes shown. Spans are shown in feet-inches and are limited to 26' and less. Check sources of supply for availability of lumber in lengths greater than 20'.

**TABLE R-5
RAFTERS WITH L/240 DEFLECTION LIMITATION**

DESIGN CRITERIA:

Strength - Live load of 20 psf plus

Dead Load of 15 psf determines the required bending design value.

Deflection - For 20 psf live load.

Limited to span in inches divided by 240.

Rafter Size (in)	Spacing (in)	Bending Design Value, F _b , (psi)																								
		300	400	500	600	700	800	900	1000	1100	1200	1300	1400	1500	1600	1700	1800	1900	2000	2100	2200	2300	2400	2500	2600	2700
2x6	12.0	6-7	7-7	8-6	9-4	10-0	10-9	11-5	12-0	12-7	13-2	13-8	14-2	14-8	15-2	15-8	16-1	16-7	17-0	17-5	17-10	-	-	-	-	-
	16.0	5-8	6-7	7-4	8-1	8-8	9-4	9-10	10-5	10-11	11-5	11-10	12-4	12-9	13-2	13-7	13-11	14-4	14-8	15-1	15-5	15-9	16-1	16-5	-	-
	19.2	5-2	6-0	6-9	7-4	7-11	8-6	9-0	9-6	9-11	10-5	10-10	11-3	11-7	12-0	12-4	12-9	13-1	13-5	13-9	14-1	14-5	14-8	15-0	15-4	-
	24.0	4-8	5-4	6-0	6-7	7-1	7-7	8-1	8-6	8-11	9-4	9-8	10-0	10-5	10-9	11-1	11-5	11-8	12-0	12-4	12-7	12-10	13-2	13-5	13-8	13-11
2x8	12.0	8-8	10-0	11-2	12-3	13-3	14-2	15-0	15-10	16-7	17-4	18-0	18-9	19-5	20-0	20-8	21-3	21-10	22-4	22-11	23-6	-	-	-	-	-
	16.0	7-6	8-8	9-8	10-7	11-6	12-3	13-0	13-8	14-4	15-0	15-7	16-3	16-9	17-4	17-10	18-5	18-11	19-5	19-10	20-4	20-9	21-3	21-8	-	-
	19.2	6-10	7-11	8-10	9-8	10-6	11-2	11-10	12-6	13-1	13-8	14-3	14-10	15-4	15-10	16-4	16-9	17-3	17-8	18-2	18-7	19-0	19-5	19-9	20-2	-
	24.0	6-2	7-1	7-11	8-8	9-4	10-0	10-7	11-2	11-9	12-3	12-9	13-3	13-8	14-2	14-7	15-0	15-5	15-10	16-3	16-7	17-0	17-4	17-8	18-0	18-5
2x10	12.0	11-1	12-9	14-3	15-8	16-11	18-1	19-2	20-2	21-2	22-1	23-0	23-11	24-9	25-6	-	-	-	-	-	-	-	-	-	-	-
	16.0	9-7	11-1	12-4	13-6	14-8	15-8	16-7	17-6	18-4	19-2	19-11	20-8	21-5	22-1	22-10	23-5	24-1	24-9	25-4	25-11	-	-	-	-	-
	19.2	8-9	10-1	11-3	12-4	13-4	14-3	15-2	15-11	16-9	17-6	18-2	18-11	19-7	20-2	20-10	21-5	22-0	22-7	23-2	23-8	24-2	24-9	25-3	25-9	-
	24.0	7-10	9-0	10-1	11-1	11-11	12-9	13-6	14-3	15-0	15-8	16-3	16-11	17-6	18-1	18-7	19-2	19-8	20-2	20-8	21-2	21-8	22-1	22-7	23-0	23-5
2x12	12.0	13-5	15-6	17-4	19-0	20-6	21-11	23-3	24-7	25-9	-	-	-	-	-	-	-	-	-	-	-	-	-	-	-	-
	16.0	11-8	13-5	15-0	16-6	17-9	19-0	20-2	21-3	22-4	23-3	24-3	25-2	26-0	-	-	-	-	-	-	-	-	-	-	-	-
	19.2	10-8	12-3	13-9	15-0	16-3	17-4	18-5	19-5	20-4	21-3	22-2	23-0	23-9	24-7	25-4	26-0	-	-	-	-	-	-	-	-	-
	24.0	9-6	11-0	12-3	13-5	14-6	15-6	16-6	17-4	18-2	19-0	19-10	20-6	21-3	21-11	22-8	23-3	23-11	24-7	25-2	25-9	-	-	-	-	-
E	12.0	0.12	0.19	0.26	0.35	0.44	0.54	0.64	0.75	0.86	0.98	1.11	1.24	1.37	1.51	1.66	1.81	1.96	2.12	2.28	2.44	-	-	-	-	-
	16.0	0.11	0.16	0.23	0.30	0.38	0.46	0.55	0.65	0.75	0.85	0.96	1.07	1.19	1.31	1.44	1.56	1.70	1.83	1.97	2.11	2.26	2.41	2.56	-	-
	19.2	0.10	0.15	0.21	0.27	0.35	0.42	0.51	0.59	0.68	0.78	0.88	0.98	1.09	1.20	1.31	1.43	1.55	1.67	1.80	1.93	2.06	2.20	2.34	2.48	-
	24.0	0.09	0.13	0.19	0.25	0.31	0.38	0.45	0.53	0.61	0.70	0.78	0.88	0.97	1.07	1.17	1.28	1.39	1.50	1.61	1.73	1.85	1.97	2.09	2.22	2.35

Note: The required modulus of elasticity, E, in 1,000,000 pounds per square inch is shown at the bottom of each table, is limited to 2.6 million psi and less, and is applicable to all lumber sizes shown. Spans are shown in feet-inches and are limited to 26' and less. Check sources of supply for availability of lumber in lengths greater than 20'.

TABLE R-6
RAFTERS WITH L/240 DEFLECTION LIMITATION

DESIGN CRITERIA:
Strength - Live load of 30 psf plus
Dead Load of 15 psf determines the required bending design value.
Deflection - For 30 psf live load.
Limited to span in inches divided by 240.

Rafter Size (in)	Spacing (in)	Bending Design Value, F _b , (psi)																								
		300	400	500	600	700	800	900	1000	1100	1200	1300	1400	1500	1600	1700	1800	1900	2000	2100	2200	2300	2400	2500	2600	2700
2x6	12.0	5-10	6-8	7-6	8-2	8-10	9-6	10-0	10-7	11-1	11-7	12-1	12-6	13-0	13-5	13-10	14-2	14-7	15-0	15-4	15-8	-	-	-	-	-
	16.0	5-0	5-10	6-6	7-1	7-8	8-2	8-8	9-2	9-7	10-0	10-5	10-10	11-3	11-7	11-11	12-4	12-8	13-0	13-3	13-7	13-11	14-2	-	-	-
	19.2	4-7	5-4	5-11	6-6	7-0	7-6	7-11	8-4	8-9	9-2	9-6	9-11	10-3	10-7	10-11	11-3	11-6	11-10	12-2	12-5	12-8	13-0	13-3	13-6	-
	24.0	4-1	4-9	5-4	5-10	6-3	6-8	7-1	7-6	7-10	8-2	8-6	8-10	9-2	9-6	9-9	10-0	10-4	10-7	10-10	11-1	11-4	11-7	11-10	12-1	12-4
2x8	12.0	7-8	8-10	9-10	10-10	11-8	12-6	13-3	13-11	14-8	15-3	15-11	16-6	17-1	17-8	18-2	18-9	19-3	19-9	20-3	20-8	-	-	-	-	-
	16.0	6-7	7-8	8-7	9-4	10-1	10-10	11-6	12-1	12-8	13-3	13-9	14-4	14-10	15-3	15-9	16-3	16-8	17-1	17-6	17-11	18-4	18-9	-	-	-
	19.2	6-1	7-0	7-10	8-7	9-3	9-10	10-6	11-0	11-7	12-1	12-7	13-1	13-6	13-11	14-5	14-10	15-2	15-7	16-0	16-4	16-9	17-1	17-5	17-9	-
	24.0	5-5	6-3	7-0	7-8	8-3	8-10	9-4	9-10	10-4	10-10	11-3	11-8	12-1	12-6	12-10	13-3	13-7	13-11	14-4	14-8	15-0	15-3	15-7	15-11	16-3
2x10	12.0	9-9	11-3	12-7	13-9	14-11	15-11	16-11	17-10	18-8	19-6	20-4	21-1	21-10	22-6	23-3	23-11	24-6	25-2	25-10	-	-	-	-	-	-
	16.0	8-5	9-9	10-11	11-11	12-11	13-9	14-8	15-5	16-2	16-11	17-7	18-3	18-11	19-6	20-1	20-8	21-3	21-10	22-4	22-10	23-5	23-11	-	-	-
	19.2	7-9	8-11	9-11	10-11	11-9	12-7	13-4	14-1	14-9	15-5	16-1	16-8	17-3	17-10	18-4	18-11	19-5	19-11	20-5	20-10	21-4	21-10	22-3	22-8	-
	24.0	6-11	8-0	8-11	9-9	10-6	11-3	11-11	12-7	13-2	13-9	14-4	14-11	15-5	15-11	16-5	16-11	17-4	17-10	18-3	18-8	19-1	19-6	19-11	20-4	20-8
2x12	12.0	11-10	13-8	15-4	16-9	18-1	19-4	20-6	21-8	22-8	23-9	24-8	25-7	-	-	-	-	-	-	-	-	-	-	-	-	-
	16.0	10-3	11-10	13-3	14-6	15-8	16-9	17-9	18-9	19-8	20-6	21-5	22-2	23-0	23-9	24-5	25-2	25-10	-	-	-	-	-	-	-	-
	19.2	9-5	10-10	12-1	13-3	14-4	15-4	16-3	17-1	17-11	18-9	19-6	20-3	21-0	21-8	22-4	23-0	23-7	24-2	24-10	25-5	25-11	-	-	-	-
	24.0	8-5	9-8	10-10	11-10	12-10	13-8	14-6	15-4	16-1	16-9	17-5	18-1	18-9	19-4	20-0	20-6	21-1	21-8	22-2	22-8	23-3	23-9	24-2	24-8	25-2
E	12.0	0.13	0.19	0.27	0.36	0.45	0.55	0.66	0.77	0.89	1.01	1.14	1.28	1.41	1.56	1.71	1.86	2.02	2.18	2.34	2.51	-	-	-	-	-
	16.0	0.11	0.17	0.24	0.31	0.39	0.48	0.57	0.67	0.77	0.88	0.99	1.10	1.22	1.35	1.48	1.61	1.75	1.89	2.03	2.18	2.33	2.48	-	-	-
	19.2	0.10	0.15	0.22	0.28	0.36	0.44	0.52	0.61	0.70	0.80	0.90	1.01	1.12	1.23	1.35	1.47	1.59	1.72	1.85	1.99	2.12	2.26	2.41	2.55	-
	24.0	0.09	0.14	0.19	0.25	0.32	0.39	0.46	0.54	0.63	0.72	0.81	0.90	1.00	1.10	1.21	1.31	1.43	1.54	1.66	1.78	1.90	2.02	2.15	2.28	2.41

Note: The required modulus of elasticity, E, in 1,000,000 pounds per square inch is shown at the bottom of each table, is limited to 2.6 million psi and less, and is applicable to all lumber sizes shown. Spans are shown in feet-inches and are limited to 26' and less. Check sources of supply for availability of lumber in lengths greater than 20'.

**TABLE R-7
RAFTERS WITH L/240 DEFLECTION LIMITATION**

DESIGN CRITERIA:
 Strength - Live load of 40 psf plus
 Dead Load of 15 psf determines the required bending design value.
 Deflection - For 40 psf live load.
 Limited to span in inches divided by 240.

Rafter Size (in)	Spacing (in)	Bending Design Value, F _b , (psi)																								
		300	400	500	600	700	800	900	1000	1100	1200	1300	1400	1500	1600	1700	1800	1900	2000	2100	2200	2300	2400	2500	2600	2700
2x6	12.0	5-3	6-1	6-9	7-5	8-0	8-7	9-1	9-7	10-0	10-6	10-11	11-4	11-9	12-1	12-6	12-10	13-2	13-6	13-10	14-2	-	-	-	-	-
	16.0	4-6	5-3	5-10	6-5	6-11	7-5	7-10	8-3	8-8	9-1	9-5	9-10	10-2	10-6	10-10	11-1	11-5	11-9	12-0	12-4	12-7	12-10	13-1	-	-
	19.2	4-2	4-9	5-4	5-10	6-4	6-9	7-2	7-7	7-11	8-3	8-8	8-11	9-3	9-7	9-10	10-2	10-5	10-8	11-0	11-3	11-6	11-9	12-0	12-2	-
	24.0	3-8	4-3	4-9	5-3	5-8	6-1	6-5	6-9	7-1	7-5	7-9	8-0	8-3	8-7	8-10	9-1	9-4	9-7	9-10	10-0	10-3	10-6	10-8	10-11	11-1
2x8	12.0	6-11	8-0	8-11	9-9	10-7	11-3	12-0	12-7	13-3	13-10	14-5	14-11	15-5	16-0	16-5	16-11	17-5	17-10	18-3	18-9	-	-	-	-	-
	16.0	6-0	6-11	7-9	8-6	9-2	9-9	10-4	10-11	11-6	12-0	12-6	12-11	13-5	13-10	14-3	14-8	15-1	15-5	15-10	16-3	16-7	16-11	17-3	-	-
	19.2	5-6	6-4	7-1	7-9	8-4	8-11	9-6	10-0	10-6	10-11	11-5	11-10	12-3	12-7	13-0	13-5	13-9	14-1	14-6	14-10	15-2	15-5	15-9	16-1	-
	24.0	4-11	5-8	6-4	6-11	7-6	8-0	8-6	8-11	9-4	9-9	10-2	10-7	10-11	11-3	11-8	12-0	12-4	12-7	12-11	13-3	13-6	13-10	14-1	14-5	14-8
2x10	12.0	8-10	10-2	11-5	12-6	13-6	14-5	15-3	16-1	16-11	17-8	18-4	19-1	19-9	20-4	21-0	21-7	22-2	22-9	23-4	23-11	-	-	-	-	-
	16.0	7-8	8-10	9-10	10-10	11-8	12-6	13-3	13-11	14-8	15-3	15-11	16-6	17-1	17-8	18-2	18-9	19-3	19-9	20-2	20-8	21-2	21-7	22-1	-	-
	19.2	7-0	8-1	9-0	9-10	10-8	11-5	12-1	12-9	13-4	13-11	14-6	15-1	15-7	16-1	16-7	17-1	17-7	18-0	18-5	18-11	19-4	19-9	20-2	20-6	-
	24.0	6-3	7-2	8-1	8-10	9-6	10-2	10-10	11-5	11-11	12-6	13-0	13-6	13-11	14-5	14-10	15-3	15-8	16-1	16-6	16-11	17-3	17-8	18-0	18-4	18-9
2x12	12.0	10-9	12-5	13-10	15-2	16-5	17-6	18-7	19-7	20-6	21-5	22-4	23-2	24-0	24-9	25-6	-	-	-	-	-	-	-	-	-	-
	16.0	9-3	10-9	12-0	13-2	14-2	15-2	16-1	17-0	17-9	18-7	19-4	20-1	20-9	21-5	22-1	22-9	23-5	24-0	24-7	25-2	25-9	-	-	-	-
	19.2	8-6	9-10	10-11	12-0	12-11	13-10	14-8	15-6	16-3	17-0	17-8	18-4	19-0	19-7	20-2	20-9	21-4	21-11	22-5	23-0	23-6	24-0	24-6	25-0	-
	24.0	7-7	8-9	9-10	10-9	11-7	12-5	13-2	13-10	14-6	15-2	15-9	16-5	17-0	17-6	18-1	18-7	19-1	19-7	20-1	20-6	21-0	21-5	21-11	22-4	22-9
E	12.0	0.12	0.19	0.27	0.35	0.44	0.54	0.65	0.76	0.88	1.00	1.13	1.26	1.40	1.54	1.68	1.83	1.99	2.15	2.31	2.48	-	-	-	-	-
	16.0	0.11	0.17	0.23	0.31	0.39	0.47	0.56	0.66	0.76	0.86	0.98	1.09	1.21	1.33	1.46	1.59	1.72	1.86	2.00	2.15	2.29	2.45	2.60	-	-
	19.2	0.10	0.15	0.21	0.28	0.35	0.43	0.51	0.60	0.69	0.79	0.89	0.99	1.10	1.22	1.33	1.45	1.57	1.70	1.83	1.96	2.09	2.23	2.37	2.52	-
	24.0	0.09	0.14	0.19	0.25	0.31	0.38	0.46	0.54	0.62	0.71	0.80	0.89	0.99	1.09	1.19	1.30	1.41	1.52	1.63	1.75	1.87	2.00	2.12	2.25	2.38

Note: The required modulus of elasticity, E, in 1,000,000 pounds per square inch is shown at the bottom of each table, is limited to 2.6 million psi and less, and is applicable to all lumber sizes shown. Spans are shown in feet-inches and are limited to 26' and less. Check sources of supply for availability of lumber in lengths greater than 20'.

TABLE R-8
RAFTERS WITH L/240 DEFLECTION LIMITATION

DESIGN CRITERIA:
Strength - Live load of 50 psf plus
Dead Load of 15 psf determines the required bending design value.
Deflection - For 50 psf live load.
Limited to span in inches divided by 240.

Rafter Size (in)	Spacing (in)	Bending Design Value, F _b , (psi)																								
		300	400	500	600	700	800	900	1000	1100	1200	1300	1400	1500	1600	1700	1800	1900	2000	2100	2200	2300	2400	2500	2600	2700
2x6	12.0	4-10	5-7	6-3	6-10	7-4	7-11	8-4	8-10	9-3	9-8	10-0	10-5	10-9	11-2	11-6	11-10	12-2	12-5	12-9	13-1	13-4	-	-	-	-
	16.0	4-2	4-10	5-5	5-11	6-5	6-10	7-3	7-8	8-0	8-4	8-8	9-0	9-4	9-8	9-11	10-3	10-6	10-9	11-1	11-4	11-7	11-10	12-1	-	-
	19.2	3-10	4-5	4-11	5-5	5-10	6-3	6-7	7-0	7-4	7-8	7-11	8-3	8-6	8-10	9-1	9-4	9-7	9-10	10-1	10-4	10-7	10-9	11-0	11-3	11-5
	24.0	3-5	3-11	4-5	4-10	5-3	5-7	5-11	6-3	6-6	6-10	7-1	7-4	7-8	7-11	8-1	8-4	8-7	8-10	9-0	9-3	9-5	9-8	9-10	10-0	10-3
2x8	12.0	6-4	7-4	8-3	9-0	9-9	10-5	11-0	11-7	12-2	12-9	13-3	13-9	14-3	14-8	15-2	15-7	16-0	16-5	16-10	17-3	17-7	-	-	-	-
	16.0	5-6	6-4	7-1	7-9	8-5	9-0	9-6	10-1	10-7	11-0	11-6	11-11	12-4	12-9	13-1	13-6	13-10	14-3	14-7	14-11	15-3	15-7	15-11	-	-
	19.2	5-0	5-10	6-6	7-1	7-8	8-3	8-8	9-2	9-8	10-1	10-6	10-10	11-3	11-7	12-0	12-4	12-8	13-0	13-4	13-7	13-11	14-3	14-6	14-10	15-1
	24.0	4-6	5-2	5-10	6-4	6-10	7-4	7-9	8-3	8-7	9-0	9-4	9-9	10-1	10-5	10-8	11-0	11-4	11-7	11-11	12-2	12-5	12-9	13-0	13-3	13-6
2x10	12.0	8-1	9-4	10-6	11-6	12-5	13-3	14-1	14-10	15-6	16-3	16-11	17-6	18-2	18-9	19-4	19-10	20-5	20-11	21-6	22-0	22-6	-	-	-	-
	16.0	7-0	8-1	9-1	9-11	10-9	11-6	12-2	12-10	13-5	14-1	14-8	15-2	15-9	16-3	16-9	17-3	17-8	18-2	18-7	19-0	19-5	19-10	20-3	-	-
	19.2	6-5	7-5	8-3	9-1	9-10	10-6	11-1	11-9	12-3	12-10	13-4	13-10	14-4	14-10	15-3	15-9	16-2	16-7	17-0	17-4	17-9	18-2	18-6	18-11	19-3
	24.0	5-9	6-7	7-5	8-1	8-9	9-4	9-11	10-6	11-0	11-6	11-11	12-5	12-10	13-3	13-8	14-1	14-5	14-10	15-2	15-6	15-11	16-3	16-7	16-11	17-3
2x12	12.0	9-10	11-5	12-9	13-11	15-1	16-1	17-1	18-0	18-11	19-9	20-6	21-4	22-1	22-9	23-6	24-2	24-10	25-6	-	-	-	-	-	-	-
	16.0	8-7	9-10	11-0	12-1	13-1	13-11	14-10	15-7	16-4	17-1	17-9	18-6	19-1	19-9	20-4	20-11	21-6	22-1	22-7	23-2	23-8	24-2	24-8	-	-
	19.2	7-10	9-0	10-1	11-0	11-11	12-9	13-6	14-3	14-11	15-7	16-3	16-10	17-5	18-0	18-7	19-1	19-8	20-2	20-8	21-1	21-7	22-1	22-6	23-0	23-5
	24.0	7-0	8-1	9-0	9-10	10-8	11-5	12-1	12-9	13-4	13-11	14-6	15-1	15-7	16-1	16-7	17-1	17-7	18-0	18-6	18-11	19-4	19-9	20-2	20-6	20-11
E	12.0	0.12	0.19	0.26	0.34	0.43	0.53	0.63	0.74	0.85	0.97	1.10	1.22	1.36	1.50	1.64	1.78	1.94	2.09	2.25	2.41	2.58	-	-	-	-
	16.0	0.11	0.16	0.23	0.30	0.37	0.46	0.55	0.64	0.74	0.84	0.95	1.06	1.18	1.30	1.42	1.55	1.68	1.81	1.95	2.09	2.23	2.38	2.53	-	-
	19.2	0.10	0.15	0.21	0.27	0.34	0.42	0.50	0.58	0.67	0.77	0.87	0.97	1.07	1.18	1.30	1.41	1.53	1.65	1.78	1.91	2.04	2.17	2.31	2.45	2.59
	24.0	0.09	0.13	0.18	0.24	0.31	0.37	0.45	0.52	0.60	0.69	0.77	0.87	0.96	1.06	1.16	1.26	1.37	1.48	1.59	1.71	1.82	1.94	2.07	2.19	2.32

Note: The required modulus of elasticity, E, in 1,000,000 pounds per square inch is shown at the bottom of each table, is limited to 2.6 million psi and less, and is applicable to all lumber sizes shown. Spans are shown in feet-inches and are limited to 26' and less. Check sources of supply for availability of lumber in lengths greater than 20'.

**TABLE R-9
RAFTERS WITH L/240 DEFLECTION LIMITATION**

DESIGN CRITERIA:
Strength - Live load of 20 psf plus
Dead Load of 20 psf determines the required bending design value.
Deflection - For 20 psf live load.
Limited to span in inches divided by 240.

Rafter Size (in)	Spacing (in)	Bending Design Value, F _b , (psi)																								
		300	400	500	600	700	800	900	1000	1100	1200	1300	1400	1500	1600	1700	1800	1900	2000	2100	2200	2300	2400	2500	2600	2700
2x6	12.0	6-2	7-1	7-11	8-8	9-5	10-0	10-8	11-3	11-9	12-4	12-10	13-3	13-9	14-2	14-8	15-1	15-6	15-11	16-3	16-8	17-0	17-5	17-9	18-1	-
	16.0	5-4	6-2	6-11	7-6	8-2	8-8	9-3	9-9	10-2	10-8	11-1	11-6	11-11	12-4	12-8	13-1	13-5	13-9	14-1	14-5	14-9	15-1	15-4	15-8	16-0
	19.2	4-10	5-7	6-3	6-11	7-5	7-11	8-5	8-11	9-4	9-9	10-1	10-6	10-10	11-3	11-7	11-11	12-3	12-7	12-10	13-2	13-6	13-9	14-0	14-4	14-7
	24.0	4-4	5-0	5-7	6-2	6-8	7-1	7-6	7-11	8-4	8-8	9-1	9-5	9-9	10-0	10-4	10-8	10-11	11-3	11-6	11-9	12-0	12-4	12-7	12-10	13-1
2x8	12.0	8-1	9-4	10-6	11-6	12-5	13-3	14-0	14-10	15-6	16-3	16-10	17-6	18-2	18-9	19-4	19-10	20-5	20-11	21-5	21-11	22-5	22-11	23-5	23-10	-
	16.0	7-0	8-1	9-1	9-11	10-9	11-6	12-2	12-10	13-5	14-0	14-7	15-2	15-8	16-3	16-9	17-2	17-8	18-2	18-7	19-0	19-5	19-10	20-3	20-8	21-1
	19.2	6-5	7-5	8-3	9-1	9-9	10-6	11-1	11-8	12-3	12-10	13-4	13-10	14-4	14-10	15-3	15-8	16-2	16-7	16-11	17-4	17-9	18-2	18-6	18-10	19-3
	24.0	5-9	6-7	7-5	8-1	8-9	9-4	9-11	10-6	11-0	11-6	11-11	12-5	12-10	13-3	13-8	14-0	14-5	14-10	15-2	15-6	15-10	16-3	16-7	16-10	17-2
2x10	12.0	10-4	11-11	13-4	14-8	15-10	16-11	17-11	18-11	19-10	20-8	21-6	22-4	23-2	23-11	24-7	25-4	26-0	-	-	-	-	-	-	-	-
	16.0	8-11	10-4	11-7	12-8	13-8	14-8	15-6	16-4	17-2	17-11	18-8	19-4	20-0	20-8	21-4	21-11	22-6	23-2	23-8	24-3	24-10	25-4	25-10	-	-
	19.2	8-2	9-5	10-7	11-7	12-6	13-4	14-2	14-11	15-8	16-4	17-0	17-8	18-3	18-11	19-6	20-0	20-7	21-1	21-8	22-2	22-8	23-2	23-7	24-1	24-6
	24.0	7-4	8-5	9-5	10-4	11-2	11-11	12-8	13-4	14-0	14-8	15-3	15-10	16-4	16-11	17-5	17-11	18-5	18-11	19-4	19-10	20-3	20-8	21-1	21-6	21-11
2x12	12.0	12-7	14-6	16-3	17-9	19-3	20-6	21-9	23-0	24-1	25-2	-	-	-	-	-	-	-	-	-	-	-	-	-	-	-
	16.0	10-11	12-7	14-1	15-5	16-8	17-9	18-10	19-11	20-10	21-9	22-8	23-6	24-4	25-2	25-11	-	-	-	-	-	-	-	-	-	-
	19.2	9-11	11-6	12-10	14-1	15-2	16-3	17-3	18-2	19-0	19-11	20-8	21-6	22-3	23-0	23-8	24-4	25-0	25-8	-	-	-	-	-	-	-
	24.0	8-11	10-3	11-6	12-7	13-7	14-6	15-5	16-3	17-0	17-9	18-6	19-3	19-11	20-6	21-2	21-9	22-5	23-0	23-6	24-1	24-8	25-2	25-8	-	-
E	12.0	0.10	0.15	0.22	0.28	0.36	0.44	0.52	0.61	0.71	0.80	0.91	1.01	1.13	1.24	1.36	1.48	1.60	1.73	1.86	2.00	2.14	2.28	2.42	2.57	-
	16.0	0.09	0.13	0.19	0.25	0.31	0.38	0.45	0.53	0.61	0.70	0.79	0.88	0.97	1.07	1.18	1.28	1.39	1.50	1.61	1.73	1.85	1.97	2.10	2.22	2.35
	19.2	0.08	0.12	0.17	0.23	0.28	0.35	0.41	0.48	0.56	0.64	0.72	0.80	0.89	0.98	1.07	1.17	1.27	1.37	1.47	1.58	1.69	1.80	1.91	2.03	2.15
	24.0	0.07	0.11	0.15	0.20	0.25	0.31	0.37	0.43	0.50	0.57	0.64	0.72	0.80	0.88	0.96	1.05	1.13	1.22	1.32	1.41	1.51	1.61	1.71	1.82	1.92

Note: The required modulus of elasticity, E, in 1,000,000 pounds per square inch is shown at the bottom of each table, is limited to 2.6 million psi and less, and is applicable to all lumber sizes shown. Spans are shown in feet-inches and are limited to 26' and less. Check sources of supply for availability of lumber in lengths greater than 20'.

TABLE R-10
RAFTERS WITH L/240 DEFLECTION LIMITATION

DESIGN CRITERIA:
Strength - Live load of 30 psf plus
Dead Load of 20 psf determines the required bending design value.
Deflection - For 30 psf live load.
Limited to span in inches divided by 240.

Rafter Size (in)	Spacing (in)	Bending Design Value, F _b , (psi)																								
		300	400	500	600	700	800	900	1000	1100	1200	1300	1400	1500	1600	1700	1800	1900	2000	2100	2200	2300	2400	2500	2600	2700
2x6	12.0	5-6	6-4	7-1	7-9	8-5	9-0	9-6	10-0	10-6	11-0	11-5	11-11	12-4	12-8	13-1	13-6	13-10	14-2	14-7	14-11	15-3	15-7	15-11	-	-
	16.0	4-9	5-6	6-2	6-9	7-3	7-9	8-3	8-8	9-1	9-6	9-11	10-3	10-8	11-0	11-4	11-8	12-0	12-4	12-7	12-11	13-2	13-6	13-9	14-0	14-3
	19.2	4-4	5-0	5-7	6-2	6-8	7-1	7-6	7-11	8-4	8-8	9-1	9-5	9-9	10-0	10-4	10-8	10-11	11-3	11-6	11-9	12-0	12-4	12-7	12-10	13-1
	24.0	3-11	4-6	5-0	5-6	5-11	6-4	6-9	7-1	7-5	7-9	8-1	8-5	8-8	9-0	9-3	9-6	9-9	10-0	10-3	10-6	10-9	11-0	11-3	11-5	11-8
2x8	12.0	7-3	8-4	9-4	10-3	11-1	11-10	12-7	13-3	13-11	14-6	15-1	15-8	16-3	16-9	17-3	17-9	18-3	18-9	19-2	19-8	20-1	20-6	20-11	-	-
	16.0	6-3	7-3	8-1	8-11	9-7	10-3	10-11	11-6	12-0	12-7	13-1	13-7	14-0	14-6	14-11	15-5	15-10	16-3	16-7	17-0	17-5	17-9	18-2	18-6	18-10
	19.2	5-9	6-7	7-5	8-1	8-9	9-4	9-11	10-6	11-0	11-6	11-11	12-5	12-10	13-3	13-8	14-0	14-5	14-10	15-2	15-6	15-10	16-3	16-7	16-10	17-2
	24.0	5-2	5-11	6-7	7-3	7-10	8-4	8-11	9-4	9-10	10-3	10-8	11-1	11-6	11-10	12-2	12-7	12-11	13-3	13-7	13-11	14-2	14-6	14-10	15-1	15-5
2x10	12.0	9-3	10-8	11-11	13-1	14-2	15-1	16-0	16-11	17-9	18-6	19-3	20-0	20-8	21-4	22-0	22-8	23-3	23-11	24-6	25-1	25-7	-	-	-	-
	16.0	8-0	9-3	10-4	11-4	12-3	13-1	13-11	14-8	15-4	16-0	16-8	17-4	17-11	18-6	19-1	19-7	20-2	20-8	21-2	21-8	22-2	22-8	23-2	23-7	24-0
	19.2	7-4	8-5	9-5	10-4	11-2	11-11	12-8	13-4	14-0	14-8	15-3	15-10	16-4	16-11	17-5	17-11	18-5	18-11	19-4	19-10	20-3	20-8	21-1	21-6	21-11
	24.0	6-6	7-7	8-5	9-3	10-0	10-8	11-4	11-11	12-6	13-1	13-7	14-2	14-8	15-1	15-7	16-0	16-6	16-11	17-4	17-9	18-1	18-6	18-11	19-3	19-7
2x12	12.0	11-3	13-0	14-6	15-11	17-2	18-4	19-6	20-6	21-7	22-6	23-5	24-4	25-2	26-0	-	-	-	-	-	-	-	-	-	-	-
	16.0	9-9	11-3	12-7	13-9	14-11	15-11	16-11	17-9	18-8	19-6	20-3	21-1	21-9	22-6	23-2	23-10	24-6	25-2	25-9	-	-	-	-	-	-
	19.2	8-11	10-3	11-6	12-7	13-7	14-6	15-5	16-3	17-0	17-9	18-6	19-3	19-11	20-6	21-2	21-9	22-5	23-0	23-6	24-1	24-8	25-2	25-8	-	-
	24.0	7-11	9-2	10-3	11-3	12-2	13-0	13-9	14-6	15-3	15-11	16-7	17-2	17-9	18-4	18-11	19-6	20-0	20-6	21-1	21-7	22-0	22-6	23-0	23-5	23-10
E	12.0	0.11	0.17	0.23	0.31	0.38	0.47	0.56	0.66	0.76	0.86	0.97	1.09	1.21	1.33	1.46	1.59	1.72	1.86	2.00	2.14	2.29	2.44	2.60	-	-
	16.0	0.09	0.14	0.20	0.26	0.33	0.41	0.49	0.57	0.66	0.75	0.84	0.94	1.05	1.15	1.26	1.37	1.49	1.61	1.73	1.86	1.99	2.12	2.25	2.39	2.53
	19.2	0.09	0.13	0.18	0.24	0.30	0.37	0.44	0.52	0.60	0.68	0.77	0.86	0.95	1.05	1.15	1.25	1.36	1.47	1.58	1.70	1.81	1.93	2.05	2.18	2.31
	24.0	0.08	0.12	0.16	0.22	0.27	0.33	0.40	0.46	0.54	0.61	0.69	0.77	0.85	0.94	1.03	1.12	1.22	1.31	1.41	1.52	1.62	1.73	1.84	1.95	2.06

Note: The required modulus of elasticity, E, in 1,000,000 pounds per square inch is shown at the bottom of each table, is limited to 2.6 million psi and less, and is applicable to all lumber sizes shown. Spans are shown in feet-inches and are limited to 26' and less. Check sources of supply for availability of lumber in lengths greater than 20'.

**TABLE R-11
RAFTERS WITH L/240 DEFLECTION LIMITATION**

DESIGN CRITERIA:

Strength - Live load of 40 psf plus

Dead Load of 20 psf determines the required bending design value.

Deflection - For 40 psf live load.

Limited to span in inches divided by 240.

Rafter Size (in)	Spacing (in)	Bending Design Value, F _b , (psi)																								
		300	400	500	600	700	800	900	1000	1100	1200	1300	1400	1500	1600	1700	1800	1900	2000	2100	2200	2300	2400	2500	2600	2700
2x6	12.0	5-0	5-10	6-6	7-1	7-8	8-2	8-8	9-2	9-7	10-0	10-5	10-10	11-3	11-7	11-11	12-4	12-8	13-0	13-3	13-7	13-11	14-2	-	-	-
	16.0	4-4	5-0	5-7	6-2	6-8	7-1	7-6	7-11	8-4	8-8	9-1	9-5	9-9	10-0	10-4	10-8	10-11	11-3	11-6	11-9	12-0	12-4	12-7	12-10	13-1
	19.2	4-0	4-7	5-1	5-7	6-1	6-6	6-11	7-3	7-7	7-11	8-3	8-7	8-11	9-2	9-5	9-9	10-0	10-3	10-6	10-9	11-0	11-3	11-6	11-8	11-11
	24.0	3-7	4-1	4-7	5-0	5-5	5-10	6-2	6-6	6-10	7-1	7-5	7-8	7-11	8-2	8-5	8-8	8-11	9-2	9-5	9-7	9-10	10-0	10-3	10-5	10-8
2x8	12.0	6-7	7-8	8-7	9-4	10-1	10-10	11-6	12-1	12-8	13-3	13-9	14-4	14-10	15-3	15-9	16-3	16-8	17-1	17-6	17-11	18-4	18-9	-	-	-
	16.0	5-9	6-7	7-5	8-1	8-9	9-4	9-11	10-6	11-0	11-6	11-11	12-5	12-10	13-3	13-8	14-0	14-5	14-10	15-2	15-6	15-10	16-3	16-7	16-10	17-2
	19.2	5-3	6-1	6-9	7-5	8-0	8-7	9-1	9-7	10-0	10-6	10-11	11-4	11-8	12-1	12-5	12-10	13-2	13-6	13-10	14-2	14-6	14-10	15-1	15-5	15-8
	24.0	4-8	5-5	6-1	6-7	7-2	7-8	8-1	8-7	9-0	9-4	9-9	10-1	10-6	10-10	11-2	11-6	11-9	12-1	12-5	12-8	12-11	13-3	13-6	13-9	14-0
2x10	12.0	8-5	9-9	10-11	11-11	12-11	13-9	14-8	15-5	16-2	16-11	17-7	18-3	18-11	19-6	20-1	20-8	21-3	21-10	22-4	22-10	23-5	23-11	-	-	-
	16.0	7-4	8-5	9-5	10-4	11-2	11-11	12-8	13-4	14-0	14-8	15-3	15-10	16-4	16-11	17-5	17-11	18-5	18-11	19-4	19-10	20-3	20-8	21-1	21-6	21-11
	19.2	6-8	7-9	8-7	9-5	10-2	10-11	11-7	12-2	12-9	13-4	13-11	14-5	14-11	15-5	15-11	16-4	16-10	17-3	17-8	18-1	18-6	18-11	19-3	19-8	20-0
	24.0	6-0	6-11	7-9	8-5	9-1	9-9	10-4	10-11	11-5	11-11	12-5	12-11	13-4	13-9	14-3	14-8	15-0	15-5	15-10	16-2	16-6	16-11	17-3	17-7	17-11
2x12	12.0	10-3	11-10	13-3	14-6	15-8	16-9	17-9	18-9	19-8	20-6	21-5	22-2	23-0	23-9	24-5	25-2	25-10	-	-	-	-	-	-	-	-
	16.0	8-11	10-3	11-6	12-7	13-7	14-6	15-5	16-3	17-0	17-9	18-6	19-3	19-11	20-6	21-2	21-9	22-5	23-0	23-6	24-1	24-8	25-2	25-8	-	-
	19.2	8-1	9-5	10-6	11-6	12-5	13-3	14-1	14-10	15-7	16-3	16-11	17-6	18-2	18-9	19-4	19-11	20-5	21-0	21-6	22-0	22-6	23-0	23-5	23-11	24-4
	24.0	7-3	8-5	9-5	10-3	11-1	11-10	12-7	13-3	13-11	14-6	15-1	15-8	16-3	16-9	17-3	17-9	18-3	18-9	19-3	19-8	20-1	20-6	21-0	21-5	21-9
E	12.0	0.11	0.17	0.24	0.31	0.39	0.48	0.57	0.67	0.77	0.88	0.99	1.10	1.22	1.35	1.48	1.61	1.75	1.89	2.03	2.18	2.33	2.48	-	-	-
	16.0	0.09	0.15	0.20	0.27	0.34	0.41	0.49	0.58	0.67	0.76	0.86	0.96	1.06	1.17	1.28	1.39	1.51	1.63	1.76	1.88	2.01	2.15	2.28	2.42	2.56
	19.2	0.09	0.13	0.19	0.24	0.31	0.38	0.45	0.53	0.61	0.69	0.78	0.87	0.97	1.07	1.17	1.27	1.38	1.49	1.60	1.72	1.84	1.96	2.08	2.21	2.34
	24.0	0.08	0.12	0.17	0.22	0.28	0.34	0.40	0.47	0.54	0.62	0.70	0.78	0.87	0.95	1.04	1.14	1.23	1.33	1.43	1.54	1.64	1.75	1.86	1.98	2.09

Note: The required modulus of elasticity, E, in 1,000,000 pounds per square inch is shown at the bottom of each table, is limited to 2.6 million psi and less, and is applicable to all lumber sizes shown. Spans are shown in feet-inches and are limited to 26' and less. Check sources of supply for availability of lumber in lengths greater than 20'.

TABLE R-12
RAFTERS WITH L/240 DEFLECTION LIMITATION

DESIGN CRITERIA:
Strength - Live load of 50 psf plus
Dead Load of 20 psf determines the required bending design value.
Deflection - For 50 psf live load.
Limited to span in inches divided by 240.

Rafter Size (in)	Spacing (in)	Bending Design Value, F _b , (psi)																								
		300	400	500	600	700	800	900	1000	1100	1200	1300	1400	1500	1600	1700	1800	1900	2000	2100	2200	2300	2400	2500	2600	2700
2x6	12.0	4-8	5-4	6-0	6-7	7-1	7-7	8-1	8-6	8-11	9-4	9-8	10-0	10-5	10-9	11-1	11-5	11-8	12-0	12-4	12-7	12-10	13-2	-	-	-
	16.0	4-0	4-8	5-2	5-8	6-2	6-7	7-0	7-4	7-9	8-1	8-5	8-8	9-0	9-4	9-7	9-10	10-2	10-5	10-8	10-11	11-2	11-5	11-7	11-10	12-1
	19.2	3-8	4-3	4-9	5-2	5-7	6-0	6-4	6-9	7-0	7-4	7-8	7-11	8-3	8-6	8-9	9-0	9-3	9-6	9-9	9-11	10-2	10-5	10-7	10-10	11-0
	24.0	3-3	3-10	4-3	4-8	5-0	5-4	5-8	6-0	6-4	6-7	6-10	7-1	7-4	7-7	7-10	8-1	8-3	8-6	8-8	8-11	9-1	9-4	9-6	9-8	9-10
2x8	12.0	6-2	7-1	7-11	8-8	9-4	10-0	10-7	11-2	11-9	12-3	12-9	13-3	13-8	14-2	14-7	15-0	15-5	15-10	16-3	16-7	17-0	17-4	-	-	-
	16.0	5-4	6-2	6-10	7-6	8-1	8-8	9-2	9-8	10-2	10-7	11-1	11-6	11-10	12-3	12-8	13-0	13-4	13-8	14-0	14-4	14-8	15-0	15-4	15-7	15-11
	19.2	4-10	5-7	6-3	6-10	7-5	7-11	8-5	8-10	9-3	9-8	10-1	10-6	10-10	11-2	11-6	11-10	12-2	12-6	12-10	13-1	13-5	13-8	14-0	14-3	14-6
	24.0	4-4	5-0	5-7	6-2	6-7	7-1	7-6	7-11	8-4	8-8	9-0	9-4	9-8	10-0	10-4	10-7	10-11	11-2	11-6	11-9	12-0	12-3	12-6	12-9	13-0
2x10	12.0	7-10	9-0	10-1	11-1	11-11	12-9	13-6	14-3	15-0	15-8	16-3	16-11	17-6	18-1	18-7	19-2	19-8	20-2	20-8	21-2	21-8	22-1	-	-	-
	16.0	6-9	7-10	8-9	9-7	10-4	11-1	11-9	12-4	13-0	13-6	14-1	14-8	15-2	15-8	16-1	16-7	17-0	17-6	17-11	18-4	18-9	19-2	19-7	19-11	20-4
	19.2	6-2	7-2	8-0	8-9	9-5	10-1	10-8	11-3	11-10	12-4	12-10	13-4	13-10	14-3	14-9	15-2	15-7	15-11	16-4	16-9	17-1	17-6	17-10	18-2	18-6
	24.0	5-6	6-5	7-2	7-10	8-5	9-0	9-7	10-1	10-7	11-1	11-6	11-11	12-4	12-9	13-2	13-6	13-11	14-3	14-8	15-0	15-4	15-8	15-11	16-3	16-7
2x12	12.0	9-6	11-0	12-3	13-5	14-6	15-6	16-6	17-4	18-2	19-0	19-10	20-6	21-3	21-11	22-8	23-3	23-11	24-7	25-2	25-9	-	-	-	-	-
	16.0	8-3	9-6	10-8	11-8	12-7	13-5	14-3	15-0	15-9	16-6	17-2	17-9	18-5	19-0	19-7	20-2	20-9	21-3	21-9	22-4	22-10	23-3	23-9	24-3	24-8
	19.2	7-6	8-8	9-8	10-8	11-6	12-3	13-0	13-9	14-5	15-0	15-8	16-3	16-10	17-4	17-11	18-5	18-11	19-5	19-11	20-4	20-10	21-3	21-8	22-2	22-7
	24.0	6-9	7-9	8-8	9-6	10-3	11-0	11-8	12-3	12-10	13-5	14-0	14-6	15-0	15-6	16-0	16-6	16-11	17-4	17-9	18-2	18-7	19-0	19-5	19-10	20-2
E	12.0	0.11	0.17	0.23	0.31	0.39	0.47	0.56	0.66	0.76	0.87	0.98	1.10	1.21	1.34	1.47	1.60	1.73	1.87	2.01	2.16	2.31	2.46	-	-	-
	16.0	0.09	0.14	0.20	0.27	0.34	0.41	0.49	0.57	0.66	0.75	0.85	0.95	1.05	1.16	1.27	1.38	1.50	1.62	1.74	1.87	2.00	2.13	2.26	2.40	2.54
	19.2	0.09	0.13	0.18	0.24	0.31	0.37	0.45	0.52	0.60	0.69	0.77	0.87	0.96	1.06	1.16	1.26	1.37	1.48	1.59	1.71	1.82	1.94	2.07	2.19	2.32
	24.0	0.08	0.12	0.17	0.22	0.27	0.33	0.40	0.47	0.54	0.61	0.69	0.77	0.86	0.95	1.04	1.13	1.22	1.32	1.42	1.53	1.63	1.74	1.85	1.96	2.07

Note: The required modulus of elasticity, E, in 1,000,000 pounds per square inch is shown at the bottom of each table, is limited to 2.6 million psi and less, and is applicable to all lumber sizes shown. Spans are shown in feet-inches and are limited to 26' and less. Check sources of supply for availability of lumber in lengths greater than 20'.

TABLE R-13
 RAFTERS WITH L/180 DEFLECTION LIMITATION

DESIGN CRITERIA:

Strength - Live load of 20 psf plus

Dead Load of 10 psf determines the required bending design value.

Deflection - For 20 psf live load.

Limited to span in inches divided by 180.

Rafter Size (in)	Spacing (in)	Bending Design Value, F_b , (psi)																														
		200	300	400	500	600	700	800	900	1000	1100	1200	1300	1400	1500	1600	1700	1800	1900	2000	2100	2200	2300	2400	2500	2600	2700	2800	2900	3000		
2x 4	12.0	3-8	4-6	5-3	5-10	6-5	6-11	7-5	7-10	8-3	8-8	9-0	9-5	9-9	10-1	10-5	10-9	11-1	11-4	11-8	11-11	12-3	12-6	-	-	-	-	-	-	-	-	
	16.0	3-2	3-11	4-6	5-1	5-6	6-0	6-5	6-9	7-2	7-6	7-10	8-2	8-5	8-9	9-0	9-4	9-7	9-10	10-1	10-4	10-7	10-10	11-1	11-4	11-6	-	-	-	-		
	19.2	2-11	3-7	4-1	4-7	5-1	5-5	5-10	6-2	6-6	6-10	7-2	7-5	7-9	8-0	8-3	8-6	8-9	9-0	9-3	9-5	9-8	9-11	10-1	10-4	10-6	10-9	-	-	-	-	
	24.0	2-7	3-2	3-8	4-1	4-6	4-11	5-3	5-6	5-10	6-1	6-5	6-8	6-11	7-2	7-5	7-7	7-10	8-0	8-3	8-5	8-8	8-10	9-0	9-3	9-5	9-7	9-9	9-11	10-1	-	
2x 6	12.0	5-10	7-1	8-2	9-2	10-0	10-10	11-7	12-4	13-0	13-7	14-2	14-9	15-4	15-11	16-5	16-11	17-5	17-10	18-4	18-9	19-3	19-8	-	-	-	-	-	-	-	-	
	16.0	5-0	6-2	7-1	7-11	8-8	9-5	10-0	10-8	11-3	11-9	12-4	12-10	13-3	13-9	14-2	14-8	15-1	15-6	15-11	16-3	16-8	17-0	17-5	17-9	18-1	-	-	-	-	-	
	19.2	4-7	5-7	6-6	7-3	7-11	8-7	9-2	9-9	10-3	10-9	11-3	11-8	12-2	12-7	13-0	13-4	13-9	14-2	14-6	14-10	15-2	15-7	15-11	16-2	16-6	16-10	-	-	-	-	
	24.0	4-1	5-0	5-10	6-6	7-1	7-8	8-2	8-8	9-2	9-7	10-0	10-5	10-10	11-3	11-7	11-11	12-4	12-8	13-0	13-3	13-7	13-11	14-2	14-6	14-9	15-1	15-4	15-7	15-11	-	
2x 8	12.0	7-8	9-4	10-10	12-1	13-3	14-4	15-3	16-3	17-1	17-11	18-9	19-6	20-3	20-11	21-7	22-3	22-11	23-7	24-2	24-9	25-4	25-11	-	-	-	-	-	-	-	-	
	16.0	6-7	8-1	9-4	10-6	11-6	12-5	13-3	14-0	14-10	15-6	16-3	16-10	17-6	18-2	18-9	19-4	19-10	20-5	20-11	21-5	21-11	22-5	22-11	23-5	23-10	-	-	-	-	-	
	19.2	6-1	7-5	8-7	9-7	10-6	11-4	12-1	12-10	13-6	14-2	14-10	15-5	16-0	16-7	17-1	17-7	18-2	18-7	19-1	19-7	20-0	20-6	20-11	21-4	21-9	22-2	-	-	-	-	-
	24.0	5-5	6-7	7-8	8-7	9-4	10-1	10-10	11-6	12-1	12-8	13-3	13-9	14-4	14-10	15-3	15-9	16-3	16-8	17-1	17-6	17-11	18-4	18-9	19-1	19-6	19-10	20-3	20-7	20-11	-	-
2x10	12.0	9-9	11-11	13-9	15-5	16-11	18-3	19-6	20-8	21-10	22-10	23-11	24-10	25-10	-	-	-	-	-	-	-	-	-	-	-	-	-	-	-	-	-	
	16.0	8-5	10-4	11-11	13-4	14-8	15-10	16-11	17-11	18-11	19-10	20-8	21-6	22-4	23-2	23-11	24-7	25-4	26-0	-	-	-	-	-	-	-	-	-	-	-	-	-
	19.2	7-9	9-5	10-11	12-2	13-4	14-5	15-5	16-4	17-3	18-1	18-11	19-8	20-5	21-1	21-10	22-6	23-2	23-9	24-5	25-0	25-7	-	-	-	-	-	-	-	-	-	-
	24.0	6-11	8-5	9-9	10-11	11-11	12-11	13-9	14-8	15-5	16-2	16-11	17-7	18-3	18-11	19-6	20-1	20-8	21-3	21-10	22-4	22-10	23-5	23-11	24-5	24-10	25-4	25-10	-	-	-	-
E	12.0	0.06	0.12	0.18	0.25	0.33	0.41	0.51	0.60	0.71	0.82	0.93	1.05	1.17	1.30	1.43	1.57	1.71	1.85	2.00	2.15	2.31	2.47	-	-	-	-	-	-	-	-	
	16.0	0.05	0.10	0.15	0.22	0.28	0.36	0.44	0.52	0.61	0.71	0.80	0.91	1.01	1.13	1.24	1.36	1.48	1.60	1.73	1.86	2.00	2.14	2.28	2.42	2.57	-	-	-	-	-	
	19.2	0.05	0.09	0.14	0.20	0.26	0.33	0.40	0.48	0.56	0.64	0.73	0.83	0.93	1.03	1.13	1.24	1.35	1.46	1.58	1.70	1.82	1.95	2.08	2.21	2.34	2.48	-	-	-	-	
	24.0	0.04	0.08	0.13	0.18	0.23	0.29	0.36	0.43	0.50	0.58	0.66	0.74	0.83	0.92	1.01	1.11	1.21	1.31	1.41	1.52	1.63	1.74	1.86	1.98	2.10	2.22	2.34	2.47	2.60	-	

Note: The required modulus of elasticity, E, in 1,000,000 pounds per square inch is shown at the bottom of each table, is limited to 2.6 million psi and less, and is applicable to all lumber sizes shown. Spans are shown in feet-inches and are limited to 26' and less. Check sources of supply for availability of lumber in lengths greater than 20'.

TABLE R-14
RAFTERS WITH L/180 DEFLECTION LIMITATION

DESIGN CRITERIA:
Strength - Live load of 30 psf plus
Dead Load of 10 psf determines the required bending design value.
Deflection - For 30 psf live load.
Limited to span in inches divided by 180.

Rafter Size (in)	Spacing (in)	Bending Design Value, F_b , (psi)																														
		200	300	400	500	600	700	800	900	1000	1100	1200	1300	1400	1500	1600	1700	1800	1900	2000	2100	2200	2300	2400	2500	2600	2700	2800	2900	3000		
2x 4	12.0	3-2	3-11	4-6	5-1	5-6	6-0	6-5	6-9	7-2	7-6	7-10	8-2	8-5	8-9	9-0	9-4	9-7	9-10	10-1	10-4	10-7	10-10	11-1	-	-	-	-	-	-	-	
	16.0	2-9	3-5	3-11	4-5	4-10	5-2	5-6	5-10	6-2	6-6	6-9	7-1	7-4	7-7	7-10	8-1	8-4	8-6	8-9	9-0	9-2	9-5	9-7	9-9	10-0	-	-	-	-	-	
	19.2	2-6	3-1	3-7	4-0	4-5	4-9	5-1	5-4	5-8	5-11	6-2	6-5	6-8	6-11	7-2	7-4	7-7	7-9	8-0	8-2	8-5	8-7	8-9	8-11	9-1	9-3	9-5	-	-	-	
	24.0	2-3	2-9	3-2	3-7	3-11	4-3	4-6	4-10	5-1	5-4	5-6	5-9	6-0	6-2	6-5	6-7	6-9	7-0	7-2	7-4	7-6	7-8	7-10	8-0	8-2	8-4	8-5	8-7	8-9	-	-
2x 6	12.0	5-0	6-2	7-1	7-11	8-8	9-5	10-0	10-8	11-3	11-9	12-4	12-10	13-3	13-9	14-2	14-8	15-1	15-6	15-11	16-3	16-8	17-0	17-5	-	-	-	-	-	-	-	
	16.0	4-4	5-4	6-2	6-11	7-6	8-2	8-8	9-3	9-9	10-2	10-8	11-1	11-6	11-11	12-4	12-8	13-1	13-5	13-9	14-1	14-5	14-9	15-1	15-4	15-8	-	-	-	-	-	
	19.2	4-0	4-10	5-7	6-3	6-11	7-5	7-11	8-5	8-11	9-4	9-9	10-1	10-6	10-10	11-3	11-7	11-11	12-3	12-7	12-10	13-2	13-6	13-9	14-0	14-4	14-7	14-10	-	-	-	
	24.0	3-7	4-4	5-0	5-7	6-2	6-8	7-1	7-6	7-11	8-4	8-8	9-1	9-5	9-9	10-0	10-4	10-8	10-11	11-3	11-6	11-9	12-0	12-4	12-7	12-10	13-1	13-3	13-6	13-9	-	-
2x 8	12.0	6-7	8-1	9-4	10-6	11-6	12-5	13-3	14-0	14-10	15-6	16-3	16-10	17-6	18-2	18-9	19-4	19-10	20-5	20-11	21-5	21-11	22-5	22-11	-	-	-	-	-	-	-	
	16.0	5-9	7-0	8-1	9-1	9-11	10-9	11-6	12-2	12-10	13-5	14-0	14-7	15-2	15-8	16-3	16-9	17-2	17-8	18-2	18-7	19-0	19-5	19-10	20-3	20-8	-	-	-	-	-	-
	19.2	5-3	6-5	7-5	8-3	9-1	9-9	10-6	11-1	11-8	12-3	12-10	13-4	13-10	14-4	14-10	15-3	15-8	16-2	16-7	16-11	17-4	17-9	18-2	18-6	18-10	19-3	19-7	-	-	-	-
	24.0	4-8	5-9	6-7	7-5	8-1	8-9	9-4	9-11	10-6	11-0	11-6	11-11	12-5	12-10	13-3	13-8	14-0	14-5	14-10	15-2	15-6	15-10	16-3	16-7	16-10	17-2	17-6	17-10	18-2	-	-
2x10	12.0	8-5	10-4	11-11	13-4	14-8	15-10	16-11	17-11	18-11	19-10	20-8	21-6	22-4	23-2	23-11	24-7	25-4	26-0	-	-	-	-	-	-	-	-	-	-	-	-	-
	16.0	7-4	8-11	10-4	11-7	12-8	13-8	14-8	15-6	16-4	17-2	17-11	18-8	19-4	20-0	20-8	21-4	21-11	22-6	23-2	23-8	24-3	24-10	25-4	25-10	-	-	-	-	-	-	-
	19.2	6-8	8-2	9-5	10-7	11-7	12-6	13-4	14-2	14-11	15-8	16-4	17-0	17-8	18-3	18-11	19-6	20-0	20-7	21-1	21-8	22-2	22-8	23-2	23-7	24-1	24-6	25-0	-	-	-	-
	24.0	6-0	7-4	8-5	9-5	10-4	11-2	11-11	12-8	13-4	14-0	14-8	15-3	15-10	16-4	16-11	17-5	17-11	18-5	18-11	19-4	19-10	20-3	20-8	21-1	21-6	21-11	22-4	22-9	23-2	-	-
E	12.0	0.06	0.11	0.17	0.24	0.32	0.40	0.49	0.59	0.69	0.79	0.91	1.02	1.14	1.27	1.39	1.53	1.66	1.80	1.95	2.10	2.25	2.40	2.56	-	-	-	-	-	-	-	
	16.0	0.05	0.10	0.15	0.21	0.28	0.35	0.43	0.51	0.60	0.69	0.78	0.88	0.99	1.10	1.21	1.32	1.44	1.56	1.69	1.82	1.95	2.08	2.22	2.36	2.50	-	-	-	-	-	
	19.2	0.05	0.09	0.14	0.19	0.25	0.32	0.39	0.47	0.54	0.63	0.72	0.81	0.90	1.00	1.10	1.21	1.32	1.43	1.54	1.66	1.78	1.90	2.03	2.15	2.28	2.42	2.55	-	-	-	-
	24.0	0.04	0.08	0.12	0.17	0.23	0.29	0.35	0.42	0.49	0.56	0.64	0.72	0.81	0.89	0.99	1.08	1.18	1.28	1.38	1.48	1.59	1.70	1.81	1.93	2.04	2.16	2.28	2.41	2.53	-	-

Note: The required modulus of elasticity, E, in 1,000,000 pounds per square inch is shown at the bottom of each table, is limited to 2.6 million psi and less, and is applicable to all lumber sizes shown. Spans are shown in feet-inches and are limited to 26' and less. Check sources of supply for availability of lumber in lengths greater than 20'.

TABLE R-15
 RAFTERS WITH L/180 DEFLECTION LIMITATION

DESIGN CRITERIA:
 Strength - Live load of 40 psf plus
 Dead Load of 10 psf determines the required bending design value.
 Deflection - For 40 psf live load.
 Limited to span in inches divided by 180.

Rafter Size (in)	Spacing (in)	Bending Design Value, F_b , (psi)																												
		200	300	400	500	600	700	800	900	1000	1100	1200	1300	1400	1500	1600	1700	1800	1900	2000	2100	2200	2300	2400	2500	2600	2700	2800	2900	3000
2x 4	12.0	2-10	3-6	4-0	4-6	4-11	5-4	5-9	6-1	6-5	6-8	7-0	7-3	7-7	7-10	8-1	8-4	8-7	8-10	9-0	9-3	9-6	9-8	9-11	10-1	-	-	-	-	-
	16.0	2-6	3-0	3-6	3-11	4-3	4-8	4-11	5-3	5-6	5-10	6-1	6-4	6-7	6-9	7-0	7-3	7-5	7-8	7-10	8-0	8-2	8-5	8-7	8-9	8-11	9-1	-	-	-
	19.2	2-3	2-9	3-2	3-7	3-11	4-3	4-6	4-10	5-1	5-4	5-6	5-9	6-0	6-2	6-5	6-7	6-9	7-0	7-2	7-4	7-6	7-8	7-10	8-0	8-2	8-4	8-5	8-7	-
	24.0	2-0	2-6	2-10	3-2	3-6	3-9	4-0	4-3	4-6	4-9	4-11	5-2	5-4	5-6	5-9	5-11	6-1	6-3	6-5	6-7	6-8	6-10	7-0	7-2	7-3	7-5	7-7	7-8	7-10
2x 6	12.0	4-6	5-6	6-4	7-1	7-9	8-5	9-0	9-6	10-0	10-6	11-0	11-5	11-11	12-4	12-8	13-1	13-6	13-10	14-2	14-7	14-11	15-3	15-7	15-11	-	-	-	-	-
	16.0	3-11	4-9	5-6	6-2	6-9	7-3	7-9	8-3	8-8	9-1	9-6	9-11	10-3	10-8	11-0	11-4	11-8	12-0	12-4	12-7	12-11	13-2	13-6	13-9	14-0	14-3	-	-	-
	19.2	3-7	4-4	5-0	5-7	6-2	6-8	7-1	7-6	7-11	8-4	8-8	9-1	9-5	9-9	10-0	10-4	10-8	10-11	11-3	11-6	11-9	12-0	12-4	12-7	12-10	13-1	13-3	13-6	-
	24.0	3-2	3-11	4-6	5-0	5-6	5-11	6-4	6-9	7-1	7-5	7-9	8-1	8-5	8-8	9-0	9-3	9-6	9-9	10-0	10-3	10-6	10-9	11-0	11-3	11-5	11-8	11-11	12-1	12-4
2x 8	12.0	5-11	7-3	8-4	9-4	10-3	11-1	11-10	12-7	13-3	13-11	14-6	15-1	15-8	16-3	16-9	17-3	17-9	18-3	18-9	19-2	19-8	20-1	20-6	20-11	-	-	-	-	-
	16.0	5-2	6-3	7-3	8-1	8-11	9-7	10-3	10-11	11-6	12-0	12-7	13-1	13-7	14-0	14-6	14-11	15-5	15-10	16-3	16-7	17-0	17-5	17-9	18-2	18-6	18-10	-	-	-
	19.2	4-8	5-9	6-7	7-5	8-1	8-9	9-4	9-11	10-6	11-0	11-6	11-11	12-5	12-10	13-3	13-8	14-0	14-5	14-10	15-2	15-6	15-10	16-3	16-7	16-10	17-2	17-6	17-10	-
	24.0	4-2	5-2	5-11	6-7	7-3	7-10	8-4	8-11	9-4	9-10	10-3	10-8	11-1	11-6	11-10	12-2	12-7	12-11	13-3	13-7	13-11	14-2	14-6	14-10	15-1	15-5	15-8	15-11	16-3
2x10	12.0	7-7	9-3	10-8	11-11	13-1	14-2	15-1	16-0	16-11	17-9	18-6	19-3	20-0	20-8	21-4	22-0	22-8	23-3	23-11	24-6	25-1	25-7	-	-	-	-	-	-	-
	16.0	6-6	8-0	9-3	10-4	11-4	12-3	13-1	13-11	14-8	15-4	16-0	16-8	17-4	17-11	18-6	19-1	19-7	20-2	20-8	21-2	21-8	22-2	22-8	23-2	23-7	24-0	-	-	-
	19.2	6-0	7-4	8-5	9-5	10-4	11-2	11-11	12-8	13-4	14-0	14-8	15-3	15-10	16-4	16-11	17-5	17-11	18-5	18-11	19-4	19-10	20-3	20-8	21-1	21-6	21-11	22-4	22-9	-
	24.0	5-4	6-6	7-7	8-5	9-3	10-0	10-8	11-4	11-11	12-6	13-1	13-7	14-2	14-8	15-1	15-7	16-0	16-6	16-11	17-4	17-9	18-1	18-6	18-11	19-3	19-7	20-0	20-4	20-8
E	12.0	0.06	0.11	0.17	0.23	0.31	0.38	0.47	0.56	0.66	0.76	0.86	0.97	1.09	1.21	1.33	1.46	1.59	1.72	1.86	2.00	2.14	2.29	2.44	2.60	-	-	-	-	-
	16.0	0.05	0.09	0.14	0.20	0.26	0.33	0.41	0.49	0.57	0.66	0.75	0.84	0.94	1.05	1.15	1.26	1.37	1.49	1.61	1.73	1.86	1.99	2.12	2.25	2.39	2.53	-	-	-
	19.2	0.05	0.09	0.13	0.18	0.24	0.30	0.37	0.44	0.52	0.60	0.68	0.77	0.86	0.95	1.05	1.15	1.25	1.36	1.47	1.58	1.70	1.81	1.93	2.05	2.18	2.31	2.43	2.57	-
	24.0	0.04	0.08	0.12	0.16	0.22	0.27	0.33	0.40	0.46	0.54	0.61	0.69	0.77	0.85	0.94	1.03	1.12	1.22	1.31	1.41	1.52	1.62	1.73	1.84	1.95	2.06	2.18	2.30	2.41

Note: The required modulus of elasticity, E, in 1,000,000 pounds per square inch is shown at the bottom of each table, is limited to 2.6 million psi and less, and is applicable to all lumber sizes shown. Spans are shown in feet-inches and are limited to 26' and less. Check sources of supply for availability of lumber in lengths greater than 20'.

TABLE R-16
RAFTERS WITH L/180 DEFLECTION LIMITATION

DESIGN CRITERIA:
Strength - Live load of 50 psf plus
Dead Load of 10 psf determines the required bending design value.
Deflection - For 50 psf live load.
Limited to span in inches divided by 180.

Rafter Size (in)	Spacing (in)	Bending Design Value, F_b , (psi)																												
		200	300	400	500	600	700	800	900	1000	1100	1200	1300	1400	1500	1600	1700	1800	1900	2000	2100	2200	2300	2400	2500	2600	2700	2800	2900	3000
2x 4	12.0	2-7	3-2	3-8	4-1	4-6	4-11	5-3	5-6	5-10	6-1	6-5	6-8	6-11	7-2	7-5	7-7	7-10	8-0	8-3	8-5	8-8	8-10	9-0	9-3	-	-	-	-	-
	16.0	2-3	2-9	3-2	3-7	3-11	4-3	4-6	4-10	5-1	5-4	5-6	5-9	6-0	6-2	6-5	6-7	6-9	7-0	7-2	7-4	7-6	7-8	7-10	8-0	8-2	8-4	8-5	-	-
	19.2	2-1	2-6	2-11	3-3	3-7	3-10	4-1	4-5	4-7	4-10	5-1	5-3	5-5	5-8	5-10	6-0	6-2	6-4	6-6	6-8	6-10	7-0	7-2	7-4	7-5	7-7	7-9	7-10	8-0
	24.0	1-10	2-3	2-7	2-11	3-2	3-5	3-8	3-11	4-1	4-4	4-6	4-8	4-11	5-1	5-3	5-5	5-6	5-8	5-10	6-0	6-1	6-3	6-5	6-6	6-8	6-9	6-11	7-0	7-2
2x 6	12.0	4-1	5-0	5-10	6-6	7-1	7-8	8-2	8-8	9-2	9-7	10-0	10-5	10-10	11-3	11-7	11-11	12-4	12-8	13-0	13-3	13-7	13-11	14-2	14-6	-	-	-	-	-
	16.0	3-7	4-4	5-0	5-7	6-2	6-8	7-1	7-6	7-11	8-4	8-8	9-1	9-5	9-9	10-0	10-4	10-8	10-11	11-3	11-6	11-9	12-0	12-4	12-7	12-10	13-1	13-3	-	-
	19.2	3-3	4-0	4-7	5-1	5-7	6-1	6-6	6-11	7-3	7-7	7-11	8-3	8-7	8-11	9-2	9-5	9-9	10-0	10-3	10-6	10-9	11-0	11-3	11-6	11-8	11-11	12-2	12-4	12-7
	24.0	2-11	3-7	4-1	4-7	5-0	5-5	5-10	6-2	6-6	6-10	7-1	7-5	7-8	7-11	8-2	8-5	8-8	8-11	9-2	9-5	9-7	9-10	10-0	10-3	10-5	10-8	10-10	11-0	11-3
2x 8	12.0	5-5	6-7	7-8	8-7	9-4	10-1	10-10	11-6	12-1	12-8	13-3	13-9	14-4	14-10	15-3	15-9	16-3	16-8	17-1	17-6	17-11	18-4	18-9	19-1	-	-	-	-	-
	16.0	4-8	5-9	6-7	7-5	8-1	8-9	9-4	9-11	10-6	11-0	11-6	11-11	12-5	12-10	13-3	13-8	14-0	14-5	14-10	15-2	15-6	15-10	16-3	16-7	16-10	17-2	17-6	-	-
	19.2	4-3	5-3	6-1	6-9	7-5	8-0	8-7	9-1	9-7	10-0	10-6	10-11	11-4	11-8	12-1	12-5	12-10	13-2	13-6	13-10	14-2	14-6	14-10	15-1	15-5	15-8	16-0	16-3	16-7
	24.0	3-10	4-8	5-5	6-1	6-7	7-2	7-8	8-1	8-7	9-0	9-4	9-9	10-1	10-6	10-10	11-2	11-6	11-9	12-1	12-5	12-8	12-11	13-3	13-6	13-9	14-0	14-4	14-7	14-10
2x10	12.0	6-11	8-5	9-9	10-11	11-11	12-11	13-9	14-8	15-5	16-2	16-11	17-7	18-3	18-11	19-6	20-1	20-8	21-3	21-10	22-4	22-10	23-5	23-11	24-5	-	-	-	-	-
	16.0	6-0	7-4	8-5	9-5	10-4	11-2	11-11	12-8	13-4	14-0	14-8	15-3	15-10	16-4	16-11	17-5	17-11	18-5	18-11	19-4	19-10	20-3	20-8	21-1	21-6	21-11	22-4	-	-
	19.2	5-5	6-8	7-9	8-7	9-5	10-2	10-11	11-7	12-2	12-9	13-4	13-11	14-5	14-11	15-5	15-11	16-4	16-10	17-3	17-8	18-1	18-6	18-11	19-3	19-8	20-0	20-5	20-9	21-1
	24.0	4-11	6-0	6-11	7-9	8-5	9-1	9-9	10-4	10-11	11-5	11-11	12-5	12-11	13-4	13-9	14-3	14-8	15-0	15-5	15-10	16-2	16-6	16-11	17-3	17-7	17-11	18-3	18-7	18-11
E	12.0	0.06	0.10	0.16	0.22	0.29	0.37	0.45	0.53	0.63	0.72	0.82	0.93	1.04	1.15	1.26	1.39	1.51	1.64	1.77	1.90	2.04	2.18	2.32	2.47	-	-	-	-	-
	16.0	0.05	0.09	0.14	0.19	0.25	0.32	0.39	0.46	0.54	0.62	0.71	0.80	0.90	0.99	1.10	1.20	1.31	1.42	1.53	1.65	1.77	1.89	2.01	2.14	2.27	2.40	2.54	-	-
	19.2	0.04	0.08	0.13	0.17	0.23	0.29	0.35	0.42	0.49	0.57	0.65	0.73	0.82	0.91	1.00	1.10	1.19	1.29	1.40	1.50	1.61	1.72	1.84	1.95	2.07	2.19	2.32	2.44	2.57
	24.0	0.04	0.07	0.11	0.16	0.21	0.26	0.32	0.38	0.44	0.51	0.58	0.66	0.73	0.81	0.89	0.98	1.07	1.16	1.25	1.34	1.44	1.54	1.64	1.75	1.85	1.96	2.07	2.18	2.30

Note: The required modulus of elasticity, E, in 1,000,000 pounds per square inch is shown at the bottom of each table, is limited to 2.6 million psi and less, and is applicable to all lumber sizes shown. Spans are shown in feet-inches and are limited to 26' and less. Check sources of supply for availability of lumber in lengths greater than 20'.

TABLE R-17
RAFTERS WITH L/180 DEFLECTION LIMITATION

DESIGN CRITERIA:
Strength - Live load of 20 psf plus
Dead Load of 15 psf determines the required bending design value.
Deflection - For 20 psf live load.
Limited to span in inches divided by 180.

Rafter Size (in)	Spacing (in)	Bending Design Value, F_b , (psi)																												
		200	300	400	500	600	700	800	900	1000	1100	1200	1300	1400	1500	1600	1700	1800	1900	2000	2100	2200	2300	2400	2500	2600	2700	2800	2900	3000
2x 4	12.0	3-5	4-2	4-10	5-5	5-11	6-5	6-10	7-3	7-8	8-0	8-4	8-8	9-0	9-4	9-8	9-11	10-3	10-6	10-10	11-1	11-4	11-7	11-10	12-1	12-4	12-7	-	-	-
	16.0	2-11	3-7	4-2	4-8	5-1	5-6	5-11	6-3	6-7	6-11	7-3	7-6	7-10	8-1	8-4	8-7	8-10	9-1	9-4	9-7	9-10	10-0	10-3	10-5	10-8	10-10	11-1	11-3	11-5
	19.2	2-8	3-4	3-10	4-3	4-8	5-1	5-5	5-9	6-0	6-4	6-7	6-11	7-2	7-5	7-8	7-10	8-1	8-4	8-6	8-9	8-11	9-2	9-4	9-7	9-9	9-11	10-1	10-3	10-5
	24.0	2-5	2-11	3-5	3-10	4-2	4-6	4-10	5-1	5-5	5-8	5-11	6-2	6-5	6-7	6-10	7-0	7-3	7-5	7-8	7-10	8-0	8-2	8-4	8-6	8-8	8-10	9-0	9-2	9-4
2x 6	12.0	5-4	6-7	7-7	8-6	9-4	10-0	10-9	11-5	12-0	12-7	13-2	13-8	14-2	14-8	15-2	15-8	16-1	16-7	17-0	17-5	17-10	18-2	18-7	19-0	19-4	19-9	-	-	-
	16.0	4-8	5-8	6-7	7-4	8-1	8-8	9-4	9-10	10-5	10-11	11-5	11-10	12-4	12-9	13-2	13-7	13-11	14-4	14-8	15-1	15-5	15-9	16-1	16-5	16-9	17-1	17-5	17-8	18-0
	19.2	4-3	5-2	6-0	6-9	7-4	7-11	8-6	9-0	9-6	9-11	10-5	10-10	11-3	11-7	12-0	12-4	12-9	13-1	13-5	13-9	14-1	14-5	14-8	15-0	15-4	15-7	15-11	16-2	16-5
	24.0	3-10	4-8	5-4	6-0	6-7	7-1	7-7	8-1	8-6	8-11	9-4	9-8	10-0	10-5	10-9	11-1	11-5	11-8	12-0	12-4	12-7	12-10	13-2	13-5	13-8	13-11	14-2	14-5	14-8
2x 8	12.0	7-1	8-8	10-0	11-2	12-3	13-3	14-2	15-0	15-10	16-7	17-4	18-0	18-9	19-5	20-0	20-8	21-3	21-10	22-4	22-11	23-6	24-0	24-6	25-0	25-6	26-0	-	-	-
	16.0	6-2	7-6	8-8	9-8	10-7	11-6	12-3	13-0	13-8	14-4	15-0	15-7	16-3	16-9	17-4	17-10	18-5	18-11	19-5	19-10	20-4	20-9	21-3	21-8	22-1	22-6	22-11	23-4	23-9
	19.2	5-7	6-10	7-11	8-10	9-8	10-6	11-2	11-10	12-6	13-1	13-8	14-3	14-10	15-4	15-10	16-4	16-9	17-3	17-8	18-2	18-7	19-0	19-5	19-9	20-2	20-7	20-11	21-4	21-8
	24.0	5-0	6-2	7-1	7-11	8-8	9-4	10-0	10-7	11-2	11-9	12-3	12-9	13-3	13-8	14-2	14-7	15-0	15-5	15-10	16-3	16-7	17-0	17-4	17-8	18-0	18-5	18-9	19-1	19-5
2x10	12.0	9-0	11-1	12-9	14-3	15-8	16-11	18-1	19-2	20-2	21-2	22-1	23-0	23-11	24-9	25-6	-	-	-	-	-	-	-	-	-	-	-	-	-	-
	16.0	7-10	9-7	11-1	12-4	13-6	14-8	15-8	16-7	17-6	18-4	19-2	19-11	20-8	21-5	22-1	22-10	23-5	24-1	24-9	25-4	25-11	-	-	-	-	-	-	-	-
	19.2	7-2	8-9	10-1	11-3	12-4	13-4	14-3	15-2	15-11	16-9	17-6	18-2	18-11	19-7	20-2	20-10	21-5	22-0	22-7	23-2	23-8	24-2	24-9	25-3	25-9	-	-	-	-
	24.0	6-5	7-10	9-0	10-1	11-1	11-11	12-9	13-6	14-3	15-0	15-8	16-3	16-11	17-6	18-1	18-7	19-2	19-8	20-2	20-8	21-2	21-8	22-1	22-7	23-0	23-5	23-11	24-4	24-9
E	12.0	0.05	0.09	0.14	0.20	0.26	0.33	0.40	0.48	0.56	0.65	0.74	0.83	0.93	1.03	1.14	1.24	1.36	1.47	1.59	1.71	1.83	1.96	2.09	2.22	2.35	2.49	-	-	-
	16.0	0.04	0.08	0.12	0.17	0.23	0.28	0.35	0.41	0.49	0.56	0.64	0.72	0.80	0.89	0.98	1.08	1.17	1.27	1.37	1.48	1.59	1.70	1.81	1.92	2.04	2.16	2.28	2.40	2.53
	19.2	0.04	0.07	0.11	0.16	0.21	0.26	0.32	0.38	0.44	0.51	0.58	0.66	0.73	0.81	0.90	0.98	1.07	1.16	1.25	1.35	1.45	1.55	1.65	1.75	1.86	1.97	2.08	2.19	2.31
	24.0	0.04	0.07	0.10	0.14	0.18	0.23	0.28	0.34	0.40	0.46	0.52	0.59	0.66	0.73	0.80	0.88	0.96	1.04	1.12	1.21	1.29	1.38	1.48	1.57	1.66	1.76	1.86	1.96	2.06

Note: The required modulus of elasticity, E, in 1,000,000 pounds per square inch is shown at the bottom of each table, is limited to 2.6 million psi and less, and is applicable to all lumber sizes shown. Spans are shown in feet-inches and are limited to 26' and less. Check sources of supply for availability of lumber in lengths greater than 20'.

TABLE R-18
RAFTERS WITH L/180 DEFLECTION LIMITATION

DESIGN CRITERIA:
Strength - Live load of 30 psf plus
Dead Load of 15 psf determines the required bending design value.
Deflection - For 30 psf live load.
Limited to span in inches divided by 180.

Rafter Size (in)	Spacing (in)	Bending Design Value, F_b , (psi)																												
		200	300	400	500	600	700	800	900	1000	1100	1200	1300	1400	1500	1600	1700	1800	1900	2000	2100	2200	2300	2400	2500	2600	2700	2800	2900	3000
2x 4	12.0	3-0	3-8	4-3	4-9	5-3	5-8	6-0	6-5	6-9	7-1	7-5	7-8	8-0	8-3	8-6	8-9	9-0	9-3	9-6	9-9	10-0	10-3	10-5	10-8	10-10	11-1	-	-	-
	16.0	2-7	3-2	3-8	4-1	4-6	4-11	5-3	5-6	5-10	6-1	6-5	6-8	6-11	7-2	7-5	7-7	7-10	8-0	8-3	8-5	8-8	8-10	9-0	9-3	9-5	9-7	9-9	9-11	10-1
	19.2	2-5	2-11	3-4	3-9	4-1	4-5	4-9	5-1	5-4	5-7	5-10	6-1	6-4	6-6	6-9	6-11	7-2	7-4	7-6	7-9	7-11	8-1	8-3	8-5	8-7	8-9	8-11	9-1	9-3
	24.0	2-2	2-7	3-0	3-4	3-8	4-0	4-3	4-6	4-9	5-0	5-3	5-5	5-8	5-10	6-0	6-3	6-5	6-7	6-9	6-11	7-1	7-3	7-5	7-6	7-8	7-10	8-0	8-1	8-3
2x 6	12.0	4-9	5-10	6-8	7-6	8-2	8-10	9-6	10-0	10-7	11-1	11-7	12-1	12-6	13-0	13-5	13-10	14-2	14-7	15-0	15-4	15-8	16-1	16-5	16-9	17-1	17-5	-	-	-
	16.0	4-1	5-0	5-10	6-6	7-1	7-8	8-2	8-8	9-2	9-7	10-0	10-5	10-10	11-3	11-7	11-11	12-4	12-8	13-0	13-3	13-7	13-11	14-2	14-6	14-9	15-1	15-4	15-7	15-11
	19.2	3-9	4-7	5-4	5-11	6-6	7-0	7-6	7-11	8-4	8-9	9-2	9-6	9-11	10-3	10-7	10-11	11-3	11-6	11-10	12-2	12-5	12-8	13-0	13-3	13-6	13-9	14-0	14-3	14-6
	24.0	3-4	4-1	4-9	5-4	5-10	6-3	6-8	7-1	7-6	7-10	8-2	8-6	8-10	9-2	9-6	9-9	10-0	10-4	10-7	10-10	11-1	11-4	11-7	11-10	12-1	12-4	12-6	12-9	13-0
2x 8	12.0	6-3	7-8	8-10	9-10	10-10	11-8	12-6	13-3	13-11	14-8	15-3	15-11	16-6	17-1	17-8	18-2	18-9	19-3	19-9	20-3	20-8	21-2	21-7	22-1	22-6	22-11	-	-	-
	16.0	5-5	6-7	7-8	8-7	9-4	10-1	10-10	11-6	12-1	12-8	13-3	13-9	14-4	14-10	15-3	15-9	16-3	16-8	17-1	17-6	17-11	18-4	18-9	19-1	19-6	19-10	20-3	20-7	20-11
	19.2	4-11	6-1	7-0	7-10	8-7	9-3	9-10	10-6	11-0	11-7	12-1	12-7	13-1	13-6	13-11	14-5	14-10	15-2	15-7	16-0	16-4	16-9	17-1	17-5	17-9	18-2	18-5	18-9	19-1
	24.0	4-5	5-5	6-3	7-0	7-8	8-3	8-10	9-4	9-10	10-4	10-10	11-3	11-8	12-1	12-6	12-10	13-3	13-7	13-11	14-4	14-8	15-0	15-3	15-7	15-11	16-3	16-6	16-10	17-1
2x10	12.0	8-0	9-9	11-3	12-7	13-9	14-11	15-11	16-11	17-10	18-8	19-6	20-4	21-1	21-10	22-6	23-3	23-11	24-6	25-2	25-10	-	-	-	-	-	-	-	-	-
	16.0	6-11	8-5	9-9	10-11	11-11	12-11	13-9	14-8	15-5	16-2	16-11	17-7	18-3	18-11	19-6	20-1	20-8	21-3	21-10	22-4	22-10	23-5	23-11	24-5	24-10	25-4	25-10	-	-
	19.2	6-4	7-9	8-11	9-11	10-11	11-9	12-7	13-4	14-1	14-9	15-5	16-1	16-8	17-3	17-10	18-4	18-11	19-5	19-11	20-5	20-10	21-4	21-10	22-3	22-8	23-2	23-7	24-0	24-5
	24.0	5-8	6-11	8-0	8-11	9-9	10-6	11-3	11-11	12-7	13-2	13-9	14-4	14-11	15-5	15-11	16-5	16-11	17-4	17-10	18-3	18-8	19-1	19-6	19-11	20-4	20-8	21-1	21-5	21-10
E	12.0	0.05	0.09	0.15	0.20	0.27	0.34	0.41	0.49	0.58	0.67	0.76	0.86	0.96	1.06	1.17	1.28	1.39	1.51	1.63	1.76	1.88	2.01	2.15	2.28	2.42	2.56	-	-	-
	16.0	0.04	0.08	0.13	0.18	0.23	0.29	0.36	0.43	0.50	0.58	0.66	0.74	0.83	0.92	1.01	1.11	1.21	1.31	1.41	1.52	1.63	1.74	1.86	1.98	2.10	2.22	2.34	2.47	2.60
	19.2	0.04	0.08	0.12	0.16	0.21	0.27	0.33	0.39	0.46	0.53	0.60	0.68	0.76	0.84	0.92	1.01	1.10	1.20	1.29	1.39	1.49	1.59	1.70	1.80	1.91	2.03	2.14	2.25	2.37
	24.0	0.04	0.07	0.10	0.14	0.19	0.24	0.29	0.35	0.41	0.47	0.54	0.61	0.68	0.75	0.83	0.90	0.99	1.07	1.15	1.24	1.33	1.42	1.52	1.61	1.71	1.81	1.91	2.02	2.12

Note: The required modulus of elasticity, E, in 1,000,000 pounds per square inch is shown at the bottom of each table, is limited to 2.6 million psi and less, and is applicable to all lumber sizes shown. Spans are shown in feet-inches and are limited to 26' and less. Check sources of supply for availability of lumber in lengths greater than 20'.

TABLE R-19
RAFTERS WITH L/180 DEFLECTION LIMITATION

DESIGN CRITERIA:
Strength - Live load of 40 psf plus
Dead Load of 15 psf determines the required bending design value.
Deflection - For 40 psf live load.
Limited to span in inches divided by 180.

Rafter Size (in)	Spacing (in)	Bending Design Value, F_b , (psi)																												
		200	300	400	500	600	700	800	900	1000	1100	1200	1300	1400	1500	1600	1700	1800	1900	2000	2100	2200	2300	2400	2500	2600	2700	2800	2900	3000
2x 4	12.0	2-9	3-4	3-10	4-4	4-9	5-1	5-5	5-9	6-1	6-5	6-8	6-11	7-3	7-6	7-8	7-11	8-2	8-5	8-7	8-10	9-0	9-3	9-5	9-8	9-10	10-0	-	-	-
	16.0	2-4	2-11	3-4	3-9	4-1	4-5	4-9	5-0	5-3	5-6	5-9	6-0	6-3	6-6	6-8	6-11	7-1	7-3	7-6	7-8	7-10	8-0	8-2	8-4	8-6	8-8	8-10	9-0	9-2
	19.2	2-2	2-8	3-1	3-5	3-9	4-0	4-4	4-7	4-10	5-1	5-3	5-6	5-8	5-11	6-1	6-3	6-6	6-8	6-10	7-0	7-2	7-4	7-6	7-7	7-9	7-11	8-1	8-2	8-4
	24.0	1-11	2-4	2-9	3-1	3-4	3-7	3-10	4-1	4-4	4-6	4-9	4-11	5-1	5-3	5-5	5-7	5-9	5-11	6-1	6-3	6-5	6-6	6-8	6-10	6-11	7-1	7-3	7-4	7-6
2x 6	12.0	4-3	5-3	6-1	6-9	7-5	8-0	8-7	9-1	9-7	10-0	10-6	10-11	11-4	11-9	12-1	12-6	12-10	13-2	13-6	13-10	14-2	14-6	14-10	15-2	15-5	15-9	-	-	-
	16.0	3-8	4-6	5-3	5-10	6-5	6-11	7-5	7-10	8-3	8-8	9-1	9-5	9-10	10-2	10-6	10-10	11-1	11-5	11-9	12-0	12-4	12-7	12-10	13-1	13-4	13-7	13-10	14-1	14-4
	19.2	3-5	4-2	4-9	5-4	5-10	6-4	6-9	7-2	7-7	7-11	8-3	8-8	8-11	9-3	9-7	9-10	10-2	10-5	10-8	11-0	11-3	11-6	11-9	12-0	12-2	12-5	12-8	12-11	13-1
	24.0	3-0	3-8	4-3	4-9	5-3	5-8	6-1	6-5	6-9	7-1	7-5	7-9	8-0	8-3	8-7	8-10	9-1	9-4	9-7	9-10	10-0	10-3	10-6	10-8	10-11	11-1	11-4	11-6	11-9
2x 8	12.0	5-8	6-11	8-0	8-11	9-9	10-7	11-3	12-0	12-7	13-3	13-10	14-5	14-11	15-5	16-0	16-5	16-11	17-5	17-10	18-3	18-9	19-2	19-7	19-11	20-4	20-9	-	-	-
	16.0	4-11	6-0	6-11	7-9	8-6	9-2	9-9	10-4	10-11	11-6	12-0	12-6	12-11	13-5	13-10	14-3	14-8	15-1	15-5	15-10	16-3	16-7	16-11	17-3	17-7	18-0	18-3	18-7	18-11
	19.2	4-6	5-6	6-4	7-1	7-9	8-4	8-11	9-6	10-0	10-6	10-11	11-5	11-10	12-3	12-7	13-0	13-5	13-9	14-1	14-6	14-10	15-2	15-5	15-9	16-1	16-5	16-8	17-0	17-3
	24.0	4-0	4-11	5-8	6-4	6-11	7-6	8-0	8-6	8-11	9-4	9-9	10-2	10-7	10-11	11-3	11-8	12-0	12-4	12-7	12-11	13-3	13-6	13-10	14-1	14-5	14-8	14-11	15-2	15-5
2x10	12.0	7-2	8-10	10-2	11-5	12-6	13-6	14-5	15-3	16-1	16-11	17-8	18-4	19-1	19-9	20-4	21-0	21-7	22-2	22-9	23-4	23-11	24-5	24-11	25-6	26-0	-	-	-	-
	16.0	6-3	7-8	8-10	9-10	10-10	11-8	12-6	13-3	13-11	14-8	15-3	15-11	16-6	17-1	17-8	18-2	18-9	19-3	19-9	20-2	20-8	21-2	21-7	22-1	22-6	22-11	23-4	23-9	24-2
	19.2	5-8	7-0	8-1	9-0	9-10	10-8	11-5	12-1	12-9	13-4	13-11	14-6	15-1	15-7	16-1	16-7	17-1	17-7	18-0	18-5	18-11	19-4	19-9	20-2	20-6	20-11	21-4	21-8	22-1
	24.0	5-1	6-3	7-2	8-1	8-10	9-6	10-2	10-10	11-5	11-11	12-6	13-0	13-6	13-11	14-5	14-10	15-3	15-8	16-1	16-6	16-11	17-3	17-8	18-0	18-4	18-9	19-1	19-5	19-9
E	12.0	0.05	0.09	0.14	0.20	0.26	0.33	0.41	0.49	0.57	0.66	0.75	0.84	0.94	1.05	1.15	1.26	1.38	1.49	1.61	1.73	1.86	1.99	2.12	2.25	2.39	2.53	-	-	-
	16.0	0.04	0.08	0.12	0.17	0.23	0.29	0.35	0.42	0.49	0.57	0.65	0.73	0.82	0.91	1.00	1.09	1.19	1.29	1.40	1.50	1.61	1.72	1.83	1.95	2.07	2.19	2.31	2.44	2.56
	19.2	0.04	0.07	0.11	0.16	0.21	0.26	0.32	0.38	0.45	0.52	0.59	0.67	0.75	0.83	0.91	1.00	1.09	1.18	1.27	1.37	1.47	1.57	1.67	1.78	1.89	2.00	2.11	2.22	2.34
	24.0	0.04	0.07	0.10	0.14	0.19	0.24	0.29	0.34	0.40	0.46	0.53	0.60	0.67	0.74	0.82	0.89	0.97	1.06	1.14	1.23	1.31	1.41	1.50	1.59	1.69	1.79	1.89	1.99	2.09

Note: The required modulus of elasticity, E, in 1,000,000 pounds per square inch is shown at the bottom of each table, is limited to 2.6 million psi and less, and is applicable to all lumber sizes shown. Spans are shown in feet-inches and are limited to 26' and less. Check sources of supply for availability of lumber in lengths greater than 20'.

TABLE R-20
RAFTERS WITH L/180 DEFLECTION LIMITATION

DESIGN CRITERIA:
Strength - Live load of 50 psf plus
Dead Load of 15 psf determines the required bending design value.
Deflection - For 50 psf live load.
Limited to span in inches divided by 180.

Rafter Size (in)	Spacing (in)	Bending Design Value, F_b , (psi)																												
		200	300	400	500	600	700	800	900	1000	1100	1200	1300	1400	1500	1600	1700	1800	1900	2000	2100	2200	2300	2400	2500	2600	2700	2800	2900	3000
2x 4	12.0	2-6	3-1	3-7	4-0	4-4	4-8	5-0	5-4	5-7	5-11	6-2	6-5	6-8	6-10	7-1	7-4	7-6	7-9	7-11	8-1	8-4	8-6	8-8	8-10	9-0	9-3	9-5	-	-
	16.0	2-2	2-8	3-1	3-5	3-9	4-1	4-4	4-7	4-10	5-1	5-4	5-6	5-9	5-11	6-2	6-4	6-6	6-8	6-10	7-0	7-2	7-4	7-6	7-8	7-10	8-0	8-1	8-3	8-5
	19.2	2-0	2-5	2-10	3-2	3-5	3-8	4-0	4-2	4-5	4-8	4-10	5-1	5-3	5-5	5-7	5-9	5-11	6-1	6-3	6-5	6-7	6-9	6-10	7-0	7-2	7-3	7-5	7-7	7-8
	24.0	1-9	2-2	2-6	2-10	3-1	3-4	3-7	3-9	4-0	4-2	4-4	4-6	4-8	4-10	5-0	5-2	5-4	5-6	5-7	5-9	5-11	6-0	6-2	6-3	6-5	6-6	6-8	6-9	6-10
2x 6	12.0	3-11	4-10	5-7	6-3	6-10	7-4	7-11	8-4	8-10	9-3	9-8	10-0	10-5	10-9	11-2	11-6	11-10	12-2	12-5	12-9	13-1	13-4	13-8	13-11	14-2	14-6	14-9	-	-
	16.0	3-5	4-2	4-10	5-5	5-11	6-5	6-10	7-3	7-8	8-0	8-4	8-8	9-0	9-4	9-8	9-11	10-3	10-6	10-9	11-1	11-4	11-7	11-10	12-1	12-4	12-6	12-9	13-0	13-3
	19.2	3-1	3-10	4-5	4-11	5-5	5-10	6-3	6-7	7-0	7-4	7-8	7-11	8-3	8-6	8-10	9-1	9-4	9-7	9-10	10-1	10-4	10-7	10-9	11-0	11-3	11-5	11-8	11-10	12-1
	24.0	2-9	3-5	3-11	4-5	4-10	5-3	5-7	5-11	6-3	6-6	6-10	7-1	7-4	7-8	7-11	8-1	8-4	8-7	8-10	9-0	9-3	9-5	9-8	9-10	10-0	10-3	10-5	10-7	10-9
2x 8	12.0	5-2	6-4	7-4	8-3	9-0	9-9	10-5	11-0	11-7	12-2	12-9	13-3	13-9	14-3	14-8	15-2	15-7	16-0	16-5	16-10	17-3	17-7	18-0	18-4	18-9	19-1	19-5	-	-
	16.0	4-6	5-6	6-4	7-1	7-9	8-5	9-0	9-6	10-1	10-7	11-0	11-6	11-11	12-4	12-9	13-1	13-6	13-10	14-3	14-7	14-11	15-3	15-7	15-11	16-3	16-6	16-10	17-1	17-5
	19.2	4-1	5-0	5-10	6-6	7-1	7-8	8-3	8-8	9-2	9-8	10-1	10-6	10-10	11-3	11-7	12-0	12-4	12-8	13-0	13-4	13-7	13-11	14-3	14-6	14-10	15-1	15-4	15-8	15-11
	24.0	3-8	4-6	5-2	5-10	6-4	6-10	7-4	7-9	8-3	8-7	9-0	9-4	9-9	10-1	10-5	10-8	11-0	11-4	11-7	11-11	12-2	12-5	12-9	13-0	13-3	13-6	13-9	14-0	14-3
2x10	12.0	6-7	8-1	9-4	10-6	11-6	12-5	13-3	14-1	14-10	15-6	16-3	16-11	17-6	18-2	18-9	19-4	19-10	20-5	20-11	21-6	22-0	22-6	22-11	23-5	23-11	24-4	24-9	-	-
	16.0	5-9	7-0	8-1	9-1	9-11	10-9	11-6	12-2	12-10	13-5	14-1	14-8	15-2	15-9	16-3	16-9	17-3	17-8	18-2	18-7	19-0	19-5	19-10	20-3	20-8	21-1	21-6	21-10	22-3
	19.2	5-3	6-5	7-5	8-3	9-1	9-10	10-6	11-1	11-9	12-3	12-10	13-4	13-10	14-4	14-10	15-3	15-9	16-2	16-7	17-0	17-4	17-9	18-2	18-6	18-11	19-3	19-7	19-11	20-3
	24.0	4-8	5-9	6-7	7-5	8-1	8-9	9-4	9-11	10-6	11-0	11-6	11-11	12-5	12-10	13-3	13-8	14-1	14-5	14-10	15-2	15-6	15-11	16-3	16-7	16-11	17-3	17-6	17-10	18-2
E	12.0	0.05	0.09	0.14	0.20	0.26	0.32	0.40	0.47	0.55	0.64	0.73	0.82	0.92	1.02	1.12	1.23	1.34	1.45	1.57	1.69	1.81	1.93	2.06	2.19	2.32	2.46	2.60	-	-
	16.0	0.04	0.08	0.12	0.17	0.22	0.28	0.34	0.41	0.48	0.55	0.63	0.71	0.80	0.88	0.97	1.06	1.16	1.26	1.36	1.46	1.57	1.67	1.78	1.90	2.01	2.13	2.25	2.37	2.49
	19.2	0.04	0.07	0.11	0.15	0.20	0.26	0.31	0.37	0.44	0.51	0.58	0.65	0.73	0.81	0.89	0.97	1.06	1.15	1.24	1.33	1.43	1.53	1.63	1.73	1.84	1.94	2.05	2.16	2.28
	24.0	0.04	0.06	0.10	0.14	0.18	0.23	0.28	0.33	0.39	0.45	0.52	0.58	0.65	0.72	0.79	0.87	0.95	1.03	1.11	1.19	1.28	1.37	1.46	1.55	1.64	1.74	1.84	1.94	2.04

Note: The required modulus of elasticity, E, in 1,000,000 pounds per square inch is shown at the bottom of each table, is limited to 2.6 million psi and less, and is applicable to all lumber sizes shown. Spans are shown in feet-inches and are limited to 26' and less. Check sources of supply for availability of lumber in lengths greater than 20'.

TABLE R-21
RAFTERS WITH L/180 DEFLECTION LIMITATION

DESIGN CRITERIA:
Strength - Live load of 20 psf plus
Dead Load of 20 psf determines the required bending design value.
Deflection - For 20 psf live load.
Limited to span in inches divided by 180.

Rafter Size (in)	Spacing (in)	Bending Design Value, F_b , (psi)																												
		200	300	400	500	600	700	800	900	1000	1100	1200	1300	1400	1500	1600	1700	1800	1900	2000	2100	2200	2300	2400	2500	2600	2700	2800	2900	3000
2x 4	12.0	3-2	3-11	4-6	5-1	5-6	6-0	6-5	6-9	7-2	7-6	7-10	8-2	8-5	8-9	9-0	9-4	9-7	9-10	10-1	10-4	10-7	10-10	11-1	11-4	11-6	11-9	11-11	12-2	12-4
	16.0	2-9	3-5	3-11	4-5	4-10	5-2	5-6	5-10	6-2	6-6	6-9	7-1	7-4	7-7	7-10	8-1	8-4	8-6	8-9	9-0	9-2	9-5	9-7	9-9	10-0	10-2	10-4	10-6	10-9
	19.2	2-6	3-1	3-7	4-0	4-5	4-9	5-1	5-4	5-8	5-11	6-2	6-5	6-8	6-11	7-2	7-4	7-7	7-9	8-0	8-2	8-5	8-7	8-9	8-11	9-1	9-3	9-5	9-7	9-9
	24.0	2-3	2-9	3-2	3-7	3-11	4-3	4-6	4-10	5-1	5-4	5-6	5-9	6-0	6-2	6-5	6-7	6-9	7-0	7-2	7-4	7-6	7-8	7-10	8-0	8-2	8-4	8-5	8-7	8-9
2x 6	12.0	5-0	6-2	7-1	7-11	8-8	9-5	10-0	10-8	11-3	11-9	12-4	12-10	13-3	13-9	14-2	14-8	15-1	15-6	15-11	16-3	16-8	17-0	17-5	17-9	18-1	18-5	18-9	19-1	19-5
	16.0	4-4	5-4	6-2	6-11	7-6	8-2	8-8	9-3	9-9	10-2	10-8	11-1	11-6	11-11	12-4	12-8	13-1	13-5	13-9	14-1	14-5	14-9	15-1	15-4	15-8	16-0	16-3	16-7	16-10
	19.2	4-0	4-10	5-7	6-3	6-11	7-5	7-11	8-5	8-11	9-4	9-9	10-1	10-6	10-10	11-3	11-7	11-11	12-3	12-7	12-10	13-2	13-6	13-9	14-0	14-4	14-7	14-10	15-1	15-4
	24.0	3-7	4-4	5-0	5-7	6-2	6-8	7-1	7-6	7-11	8-4	8-8	9-1	9-5	9-9	10-0	10-4	10-8	10-11	11-3	11-6	11-9	12-0	12-4	12-7	12-10	13-1	13-3	13-6	13-9
2x 8	12.0	6-7	8-1	9-4	10-6	11-6	12-5	13-3	14-0	14-10	15-6	16-3	16-10	17-6	18-2	18-9	19-4	19-10	20-5	20-11	21-5	21-11	22-5	22-11	23-5	23-10	24-4	24-9	25-2	25-8
	16.0	5-9	7-0	8-1	9-1	9-11	10-9	11-6	12-2	12-10	13-5	14-0	14-7	15-2	15-8	16-3	16-9	17-2	17-8	18-2	18-7	19-0	19-5	19-10	20-3	20-8	21-1	21-5	21-10	22-2
	19.2	5-3	6-5	7-5	8-3	9-1	9-9	10-6	11-1	11-8	12-3	12-10	13-4	13-10	14-4	14-10	15-3	15-8	16-2	16-7	16-11	17-4	17-9	18-2	18-6	18-10	19-3	19-7	19-11	20-3
	24.0	4-8	5-9	6-7	7-5	8-1	8-9	9-4	9-11	10-6	11-0	11-6	11-11	12-5	12-10	13-3	13-8	14-0	14-5	14-10	15-2	15-6	15-10	16-3	16-7	16-10	17-2	17-6	17-10	18-2
2x10	12.0	8-5	10-4	11-11	13-4	14-8	15-10	16-11	17-11	18-11	19-10	20-8	21-6	22-4	23-2	23-11	24-7	25-4	26-0	-	-	-	-	-	-	-	-	-	-	-
	16.0	7-4	8-11	10-4	11-7	12-8	13-8	14-8	15-6	16-4	17-2	17-11	18-8	19-4	20-0	20-8	21-4	21-11	22-6	23-2	23-8	24-3	24-10	25-4	25-10	-	-	-	-	-
	19.2	6-8	8-2	9-5	10-7	11-7	12-6	13-4	14-2	14-11	15-8	16-4	17-0	17-8	18-3	18-11	19-6	20-0	20-7	21-1	21-8	22-2	22-8	23-2	23-7	24-1	24-6	25-0	25-5	25-10
	24.0	6-0	7-4	8-5	9-5	10-4	11-2	11-11	12-8	13-4	14-0	14-8	15-3	15-10	16-4	16-11	17-5	17-11	18-5	18-11	19-4	19-10	20-3	20-8	21-1	21-6	21-11	22-4	22-9	23-2
E	12.0	0.04	0.08	0.12	0.16	0.21	0.27	0.33	0.39	0.46	0.53	0.60	0.68	0.76	0.84	0.93	1.02	1.11	1.20	1.30	1.40	1.50	1.60	1.71	1.82	1.93	2.04	2.15	2.27	2.39
	16.0	0.04	0.07	0.10	0.14	0.18	0.23	0.28	0.34	0.40	0.46	0.52	0.59	0.66	0.73	0.80	0.88	0.96	1.04	1.13	1.21	1.30	1.39	1.48	1.57	1.67	1.76	1.86	1.96	2.07
	19.2	0.03	0.06	0.09	0.13	0.17	0.21	0.26	0.31	0.36	0.42	0.48	0.54	0.60	0.67	0.73	0.80	0.88	0.95	1.03	1.10	1.18	1.27	1.35	1.44	1.52	1.61	1.70	1.79	1.89
	24.0	0.03	0.05	0.08	0.11	0.15	0.19	0.23	0.28	0.32	0.37	0.43	0.48	0.54	0.60	0.66	0.72	0.78	0.85	0.92	0.99	1.06	1.13	1.21	1.28	1.36	1.44	1.52	1.60	1.69

Note: The required modulus of elasticity, E, in 1,000,000 pounds per square inch is shown at the bottom of each table, is limited to 2.6 million psi and less, and is applicable to all lumber sizes shown. Spans are shown in feet-inches and are limited to 26' and less. Check sources of supply for availability of lumber in lengths greater than 20'.

TABLE R-22
RAFTERS WITH L/180 DEFLECTION LIMITATION

DESIGN CRITERIA:
Strength - Live load of 30 psf plus
Dead Load of 20 psf determines the required bending design value.
Deflection - For 30 psf live load.
Limited to span in inches divided by 180.

Rafter Size (in)	Spacing (in)	Bending Design Value, F_b , (psi)																												
		200	300	400	500	600	700	800	900	1000	1100	1200	1300	1400	1500	1600	1700	1800	1900	2000	2100	2200	2300	2400	2500	2600	2700	2800	2900	3000
2x 4	12.0	2-10	3-6	4-0	4-6	4-11	5-4	5-9	6-1	6-5	6-8	7-0	7-3	7-7	7-10	8-1	8-4	8-7	8-10	9-0	9-3	9-6	9-8	9-11	10-1	10-4	10-6	10-8	10-11	11-1
	16.0	2-6	3-0	3-6	3-11	4-3	4-8	4-11	5-3	5-6	5-10	6-1	6-4	6-7	6-9	7-0	7-3	7-5	7-8	7-10	8-0	8-2	8-5	8-7	8-9	8-11	9-1	9-3	9-5	9-7
	19.2	2-3	2-9	3-2	3-7	3-11	4-3	4-6	4-10	5-1	5-4	5-6	5-9	6-0	6-2	6-5	6-7	6-9	7-0	7-2	7-4	7-6	7-8	7-10	8-0	8-2	8-4	8-5	8-7	8-9
	24.0	2-0	2-6	2-10	3-2	3-6	3-9	4-0	4-3	4-6	4-9	4-11	5-2	5-4	5-6	5-9	5-11	6-1	6-3	6-5	6-7	6-8	6-10	7-0	7-2	7-3	7-5	7-7	7-8	7-10
2x 6	12.0	4-6	5-6	6-4	7-1	7-9	8-5	9-0	9-6	10-0	10-6	11-0	11-5	11-11	12-4	12-8	13-1	13-6	13-10	14-2	14-7	14-11	15-3	15-7	15-11	16-2	16-6	16-10	17-1	17-5
	16.0	3-11	4-9	5-6	6-2	6-9	7-3	7-9	8-3	8-8	9-1	9-6	9-11	10-3	10-8	11-0	11-4	11-8	12-0	12-4	12-7	12-11	13-2	13-6	13-9	14-0	14-3	14-7	14-10	15-1
	19.2	3-7	4-4	5-0	5-7	6-2	6-8	7-1	7-6	7-11	8-4	8-8	9-1	9-5	9-9	10-0	10-4	10-8	10-11	11-3	11-6	11-9	12-0	12-4	12-7	12-10	13-1	13-3	13-6	13-9
	24.0	3-2	3-11	4-6	5-0	5-6	5-11	6-4	6-9	7-1	7-5	7-9	8-1	8-5	8-8	9-0	9-3	9-6	9-9	10-0	10-3	10-6	10-9	11-0	11-3	11-5	11-8	11-11	12-1	12-4
2x 8	12.0	5-11	7-3	8-4	9-4	10-3	11-1	11-10	12-7	13-3	13-11	14-6	15-1	15-8	16-3	16-9	17-3	17-9	18-3	18-9	19-2	19-8	20-1	20-6	20-11	21-4	21-9	22-2	22-6	22-11
	16.0	5-2	6-3	7-3	8-1	8-11	9-7	10-3	10-11	11-6	12-0	12-7	13-1	13-7	14-0	14-6	14-11	15-5	15-10	16-3	16-7	17-0	17-5	17-9	18-2	18-6	18-10	19-2	19-6	19-10
	19.2	4-8	5-9	6-7	7-5	8-1	8-9	9-4	9-11	10-6	11-0	11-6	11-11	12-5	12-10	13-3	13-8	14-0	14-5	14-10	15-2	15-6	15-10	16-3	16-7	16-10	17-2	17-6	17-10	18-2
	24.0	4-2	5-2	5-11	6-7	7-3	7-10	8-4	8-11	9-4	9-10	10-3	10-8	11-1	11-6	11-10	12-2	12-7	12-11	13-3	13-7	13-11	14-2	14-6	14-10	15-1	15-5	15-8	15-11	16-3
2x10	12.0	7-7	9-3	10-8	11-11	13-1	14-2	15-1	16-0	16-11	17-9	18-6	19-3	20-0	20-8	21-4	22-0	22-8	23-3	23-11	24-6	25-1	25-7	-	-	-	-	-	-	-
	16.0	6-6	8-0	9-3	10-4	11-4	12-3	13-1	13-11	14-8	15-4	16-0	16-8	17-4	17-11	18-6	19-1	19-7	20-2	20-8	21-2	21-8	22-2	22-8	23-2	23-7	24-0	24-6	24-11	25-4
	19.2	6-0	7-4	8-5	9-5	10-4	11-2	11-11	12-8	13-4	14-0	14-8	15-3	15-10	16-4	16-11	17-5	17-11	18-5	18-11	19-4	19-10	20-3	20-8	21-1	21-6	21-11	22-4	22-9	23-2
	24.0	5-4	6-6	7-7	8-5	9-3	10-0	10-8	11-4	11-11	12-6	13-1	13-7	14-2	14-8	15-1	15-7	16-0	16-6	16-11	17-4	17-9	18-1	18-6	18-11	19-3	19-7	20-0	20-4	20-8
E	12.0	0.04	0.08	0.12	0.17	0.23	0.29	0.35	0.42	0.49	0.57	0.65	0.73	0.82	0.91	1.00	1.09	1.19	1.29	1.39	1.50	1.61	1.72	1.83	1.95	2.07	2.19	2.31	2.43	2.56
	16.0	0.04	0.07	0.11	0.15	0.20	0.25	0.31	0.36	0.43	0.49	0.56	0.63	0.71	0.78	0.86	0.95	1.03	1.12	1.21	1.30	1.39	1.49	1.59	1.69	1.79	1.89	2.00	2.11	2.22
	19.2	0.03	0.06	0.10	0.14	0.18	0.23	0.28	0.33	0.39	0.45	0.51	0.58	0.65	0.72	0.79	0.86	0.94	1.02	1.10	1.19	1.27	1.36	1.45	1.54	1.63	1.73	1.83	1.92	2.03
	24.0	0.03	0.06	0.09	0.12	0.16	0.20	0.25	0.30	0.35	0.40	0.46	0.52	0.58	0.64	0.71	0.77	0.84	0.91	0.99	1.06	1.14	1.22	1.30	1.38	1.46	1.55	1.63	1.72	1.81

Note: The required modulus of elasticity, E, in 1,000,000 pounds per square inch is shown at the bottom of each table, is limited to 2.6 million psi and less, and is applicable to all lumber sizes shown. Spans are shown in feet-inches and are limited to 26' and less. Check sources of supply for availability of lumber in lengths greater than 20'.

TABLE R-23
RAFTERS WITH L/180 DEFLECTION LIMITATION

DESIGN CRITERIA:
Strength - Live load of 40 psf plus
Dead Load of 20 psf determines the required bending design value.
Deflection - For 40 psf live load.
Limited to span in inches divided by 180.

Rafter Size (in)	Spacing (in)	Bending Design Value, F_b , (psi)																												
		200	300	400	500	600	700	800	900	1000	1100	1200	1300	1400	1500	1600	1700	1800	1900	2000	2100	2200	2300	2400	2500	2600	2700	2800	2900	3000
2x 4	12.0	2-7	3-2	3-8	4-1	4-6	4-11	5-3	5-6	5-10	6-1	6-5	6-8	6-11	7-2	7-5	7-7	7-10	8-0	8-3	8-5	8-8	8-10	9-0	9-3	9-5	9-7	9-9	9-11	10-1
	16.0	2-3	2-9	3-2	3-7	3-11	4-3	4-6	4-10	5-1	5-4	5-6	5-9	6-0	6-2	6-5	6-7	6-9	7-0	7-2	7-4	7-6	7-8	7-10	8-0	8-2	8-4	8-5	8-7	8-9
	19.2	2-1	2-6	2-11	3-3	3-7	3-10	4-1	4-5	4-7	4-10	5-1	5-3	5-5	5-8	5-10	6-0	6-2	6-4	6-6	6-8	6-10	7-0	7-2	7-4	7-5	7-7	7-9	7-10	8-0
	24.0	1-10	2-3	2-7	2-11	3-2	3-5	3-8	3-11	4-1	4-4	4-6	4-8	4-11	5-1	5-3	5-5	5-6	5-8	5-10	6-0	6-1	6-3	6-5	6-6	6-8	6-9	6-11	7-0	7-2
2x 6	12.0	4-1	5-0	5-10	6-6	7-1	7-8	8-2	8-8	9-2	9-7	10-0	10-5	10-10	11-3	11-7	11-11	12-4	12-8	13-0	13-3	13-7	13-11	14-2	14-6	14-9	15-1	15-4	15-7	15-11
	16.0	3-7	4-4	5-0	5-7	6-2	6-8	7-1	7-6	7-11	8-4	8-8	9-1	9-5	9-9	10-0	10-4	10-8	10-11	11-3	11-6	11-9	12-0	12-4	12-7	12-10	13-1	13-3	13-6	13-9
	19.2	3-3	4-0	4-7	5-1	5-7	6-1	6-6	6-11	7-3	7-7	7-11	8-3	8-7	8-11	9-2	9-5	9-9	10-0	10-3	10-6	10-9	11-0	11-3	11-6	11-8	11-11	12-2	12-4	12-7
	24.0	2-11	3-7	4-1	4-7	5-0	5-5	5-10	6-2	6-6	6-10	7-1	7-5	7-8	7-11	8-2	8-5	8-8	8-11	9-2	9-5	9-7	9-10	10-0	10-3	10-5	10-8	10-10	11-0	11-3
2x 8	12.0	5-5	6-7	7-8	8-7	9-4	10-1	10-10	11-6	12-1	12-8	13-3	13-9	14-4	14-10	15-3	15-9	16-3	16-8	17-1	17-6	17-11	18-4	18-9	19-1	19-6	19-10	20-3	20-7	20-11
	16.0	4-8	5-9	6-7	7-5	8-1	8-9	9-4	9-11	10-6	11-0	11-6	11-11	12-5	12-10	13-3	13-8	14-0	14-5	14-10	15-2	15-6	15-10	16-3	16-7	16-10	17-2	17-6	17-10	18-2
	19.2	4-3	5-3	6-1	6-9	7-5	8-0	8-7	9-1	9-7	10-0	10-6	10-11	11-4	11-8	12-1	12-5	12-10	13-2	13-6	13-10	14-2	14-6	14-10	15-1	15-5	15-8	16-0	16-3	16-7
	24.0	3-10	4-8	5-5	6-1	6-7	7-2	7-8	8-1	8-7	9-0	9-4	9-9	10-1	10-6	10-10	11-2	11-6	11-9	12-1	12-5	12-8	12-11	13-3	13-6	13-9	14-0	14-4	14-7	14-10
2x10	12.0	6-11	8-5	9-9	10-11	11-11	12-11	13-9	14-8	15-5	16-2	16-11	17-7	18-3	18-11	19-6	20-1	20-8	21-3	21-10	22-4	22-10	23-5	23-11	24-5	24-10	25-4	25-10	-	-
	16.0	6-0	7-4	8-5	9-5	10-4	11-2	11-11	12-8	13-4	14-0	14-8	15-3	15-10	16-4	16-11	17-5	17-11	18-5	18-11	19-4	19-10	20-3	20-8	21-1	21-6	21-11	22-4	22-9	23-2
	19.2	5-5	6-8	7-9	8-7	9-5	10-2	10-11	11-7	12-2	12-9	13-4	13-11	14-5	14-11	15-5	15-11	16-4	16-10	17-3	17-8	18-1	18-6	18-11	19-3	19-8	20-0	20-5	20-9	21-1
	24.0	4-11	6-0	6-11	7-9	8-5	9-1	9-9	10-4	10-11	11-5	11-11	12-5	12-11	13-4	13-9	14-3	14-8	15-0	15-5	15-10	16-2	16-6	16-11	17-3	17-7	17-11	18-3	18-7	18-11
E	12.0	0.04	0.08	0.13	0.18	0.23	0.29	0.36	0.43	0.50	0.58	0.66	0.74	0.83	0.92	1.01	1.11	1.21	1.31	1.41	1.52	1.63	1.74	1.86	1.98	2.10	2.22	2.34	2.47	2.60
	16.0	0.04	0.07	0.11	0.15	0.20	0.25	0.31	0.37	0.43	0.50	0.57	0.64	0.72	0.80	0.88	0.96	1.05	1.13	1.22	1.32	1.41	1.51	1.61	1.71	1.82	1.92	2.03	2.14	2.25
	19.2	0.04	0.06	0.10	0.14	0.18	0.23	0.28	0.34	0.40	0.46	0.52	0.59	0.65	0.73	0.80	0.88	0.95	1.04	1.12	1.20	1.29	1.38	1.47	1.56	1.66	1.75	1.85	1.95	2.05
	24.0	0.03	0.06	0.09	0.13	0.16	0.21	0.25	0.30	0.35	0.41	0.46	0.52	0.59	0.65	0.72	0.78	0.85	0.93	1.00	1.08	1.15	1.23	1.31	1.40	1.48	1.57	1.66	1.75	1.84

Note: The required modulus of elasticity, E, in 1,000,000 pounds per square inch is shown at the bottom of each table, is limited to 2.6 million psi and less, and is applicable to all lumber sizes shown. Spans are shown in feet-inches and are limited to 26' and less. Check sources of supply for availability of lumber in lengths greater than 20'.

TABLE R-24
RAFTERS WITH L/180 DEFLECTION LIMITATION

DESIGN CRITERIA:
Strength - Live load of 50 psf plus
Dead Load of 20 psf determines the required bending design value.
Deflection - For 50 psf live load.
Limited to span in inches divided by 180.

Rafter Size (in)	Spacing (in)	Bending Design Value, F_b , (psi)																												
		200	300	400	500	600	700	800	900	1000	1100	1200	1300	1400	1500	1600	1700	1800	1900	2000	2100	2200	2300	2400	2500	2600	2700	2800	2900	3000
2x 4	12.0	2-5	2-11	3-5	3-10	4-2	4-6	4-10	5-1	5-5	5-8	5-11	6-2	6-5	6-7	6-10	7-0	7-3	7-5	7-8	7-10	8-0	8-2	8-4	8-6	8-8	8-10	9-0	9-2	9-4
	16.0	2-1	2-7	2-11	3-4	3-7	3-11	4-2	4-5	4-8	4-11	5-1	5-4	5-6	5-9	5-11	6-1	6-3	6-5	6-7	6-9	6-11	7-1	7-3	7-5	7-6	7-8	7-10	8-0	8-1
	19.2	1-11	2-4	2-8	3-0	3-4	3-7	3-10	4-1	4-3	4-6	4-8	4-10	5-1	5-3	5-5	5-7	5-9	5-11	6-0	6-2	6-4	6-6	6-7	6-9	6-11	7-0	7-2	7-3	7-5
	24.0	1-8	2-1	2-5	2-8	2-11	3-2	3-5	3-7	3-10	4-0	4-2	4-4	4-6	4-8	4-10	5-0	5-1	5-3	5-5	5-6	5-8	5-9	5-11	6-0	6-2	6-3	6-5	6-6	6-7
2x 6	12.0	3-10	4-8	5-4	6-0	6-7	7-1	7-7	8-1	8-6	8-11	9-4	9-8	10-0	10-5	10-9	11-1	11-5	11-8	12-0	12-4	12-7	12-10	13-2	13-5	13-8	13-11	14-2	14-5	14-8
	16.0	3-3	4-0	4-8	5-2	5-8	6-2	6-7	7-0	7-4	7-9	8-1	8-5	8-8	9-0	9-4	9-7	9-10	10-2	10-5	10-8	10-11	11-2	11-5	11-7	11-10	12-1	12-4	12-6	12-9
	19.2	3-0	3-8	4-3	4-9	5-2	5-7	6-0	6-4	6-9	7-0	7-4	7-8	7-11	8-3	8-6	8-9	9-0	9-3	9-6	9-9	9-11	10-2	10-5	10-7	10-10	11-0	11-3	11-5	11-7
	24.0	2-8	3-3	3-10	4-3	4-8	5-0	5-4	5-8	6-0	6-4	6-7	6-10	7-1	7-4	7-7	7-10	8-1	8-3	8-6	8-8	8-11	9-1	9-4	9-6	9-8	9-10	10-0	10-3	10-5
2x 8	12.0	5-0	6-2	7-1	7-11	8-8	9-4	10-0	10-7	11-2	11-9	12-3	12-9	13-3	13-8	14-2	14-7	15-0	15-5	15-10	16-3	16-7	17-0	17-4	17-8	18-0	18-5	18-9	19-1	19-5
	16.0	4-4	5-4	6-2	6-10	7-6	8-1	8-8	9-2	9-8	10-2	10-7	11-1	11-6	11-10	12-3	12-8	13-0	13-4	13-8	14-0	14-4	14-8	15-0	15-4	15-7	15-11	16-3	16-6	16-9
	19.2	3-11	4-10	5-7	6-3	6-10	7-5	7-11	8-5	8-10	9-3	9-8	10-1	10-6	10-10	11-2	11-6	11-10	12-2	12-6	12-10	13-1	13-5	13-8	14-0	14-3	14-6	14-10	15-1	15-4
	24.0	3-6	4-4	5-0	5-7	6-2	6-7	7-1	7-6	7-11	8-4	8-8	9-0	9-4	9-8	10-0	10-4	10-7	10-11	11-2	11-6	11-9	12-0	12-3	12-6	12-9	13-0	13-3	13-6	13-8
2x10	12.0	6-5	7-10	9-0	10-1	11-1	11-11	12-9	13-6	14-3	15-0	15-8	16-3	16-11	17-6	18-1	18-7	19-2	19-8	20-2	20-8	21-2	21-8	22-1	22-7	23-0	23-5	23-11	24-4	24-9
	16.0	5-6	6-9	7-10	8-9	9-7	10-4	11-1	11-9	12-4	13-0	13-6	14-1	14-8	15-2	15-8	16-1	16-7	17-0	17-6	17-11	18-4	18-9	19-2	19-7	19-11	20-4	20-8	21-1	21-5
	19.2	5-1	6-2	7-2	8-0	8-9	9-5	10-1	10-8	11-3	11-10	12-4	12-10	13-4	13-10	14-3	14-9	15-2	15-7	15-11	16-4	16-9	17-1	17-6	17-10	18-2	18-6	18-11	19-3	19-7
	24.0	4-6	5-6	6-5	7-2	7-10	8-5	9-0	9-7	10-1	10-7	11-1	11-6	11-11	12-4	12-9	13-2	13-6	13-11	14-3	14-8	15-0	15-4	15-8	15-11	16-3	16-7	16-11	17-2	17-6
E	12.0	0.04	0.08	0.13	0.18	0.23	0.29	0.35	0.42	0.50	0.57	0.65	0.74	0.82	0.91	1.00	1.10	1.20	1.30	1.40	1.51	1.62	1.73	1.84	1.96	2.08	2.20	2.32	2.45	2.58
	16.0	0.04	0.07	0.11	0.15	0.20	0.25	0.31	0.37	0.43	0.50	0.56	0.64	0.71	0.79	0.87	0.95	1.04	1.12	1.21	1.31	1.40	1.50	1.60	1.70	1.80	1.91	2.01	2.12	2.23
	19.2	0.04	0.06	0.10	0.14	0.18	0.23	0.28	0.33	0.39	0.45	0.52	0.58	0.65	0.72	0.79	0.87	0.95	1.03	1.11	1.19	1.28	1.37	1.46	1.55	1.64	1.74	1.84	1.94	2.04
	24.0	0.03	0.06	0.09	0.12	0.16	0.21	0.25	0.30	0.35	0.40	0.46	0.52	0.58	0.64	0.71	0.78	0.85	0.92	0.99	1.07	1.14	1.22	1.30	1.39	1.47	1.56	1.64	1.73	1.82

Note: The required modulus of elasticity, E, in 1,000,000 pounds per square inch is shown at the bottom of each table, is limited to 2.6 million psi and less, and is applicable to all lumber sizes shown. Spans are shown in feet-inches and are limited to 26' and less. Check sources of supply for availability of lumber in lengths greater than 20'.

APPENDIX A - COMMENTARY

A.1 Floor Joists

A.1.1 Floor Joists with L/360 Deflection Limitations

Tables F-1 through F-7 list spans for floor joists, used over a single span, with calculations based on modulus of elasticity, E, and the required bending design values, F_b , shown. Floor joist spans are determined based on a deflection limitation of L/360, where L is the span in inches. The deflection equation for a simple span beam with uniformly distributed load is:

$$\Delta_{\max} = \frac{5wL^4}{384EI} \quad [\text{Eq. A.1-1}]$$

Since $\Delta_{\max} \leq L/360$ this equation can be rewritten to solve for L as follows:

$$L = \sqrt[3]{\frac{384EI}{5w(360)}} \quad [\text{Eq. A.1-2}]$$

The uniform load, w, is based on the live load and joist spacing. The moment of inertia, I, is based on the joist size.

The required bending design value, F_b , is determined based on the calculated span. Note that the maximum moment, M_{\max} , of a single span beam with uniform load is calculated as:

$$M_{\max} = \frac{wL^2}{8} \quad [\text{Eq. A.1-3}]$$

where the uniform load, w, is based on the total dead plus live load and joist spacing. The actual bending stress in a beam is calculated as $f_b = M/S$ where S is the section modulus of the joist. The allowable bending design value, F_b , is based on a fully supported member, properly sheathed and nailed on the top edge of the joist. Since the actual stress must be less than the allowable bending design value, F_b , the allowable bending design value can be calculated as:

$$F_b = \frac{wL^2}{8S} \quad [\text{Eq. A.1-4}]$$

A.1.2 Floor Joists with L/480 or L/600 Deflection Limitations

Most codes require a minimum deflection limitation of L/360 for floor joists. In cases where a stricter deflection limit is desired, and the length shown is controlled by the L/360 deflection limit, the tabulated span lengths may be adjusted by the factors shown as follows:

Deflection Limit	Adjustment Factor
L/480	0.91
L/600	0.84

A.1.3 Two-Span Floor Joists

Tables F-1 through F-7 list spans based on floor joists with a uniform load over one span. Calculations are based on E with required F_b values shown. Note that a uniform live load acting on equal spans of a continuous two-span joist will create less deflection and stress than an identical uniform load acting on a single span joist. Therefore, Tables F-1 through F-7 may conservatively be used for continuous, two-span joists supporting a uniform load. Note also that the required compression design value perpendicular to grain at the center support will be twice that required for a single span joist as shown in Table 9.1.

A.2 Ceiling Joists

Tables C-1 and C-2 list spans for ceiling joists used over a single span with calculations based on E and the required F_b values shown. The spans and required bending design values are determined from the same equations for a single span, uniformly loaded beam as shown above for single span floor joists. The only difference in design criteria is L/240 deflection limitations for ceiling joists supporting drywall ceilings which are typically required by building codes. The allowable bending design value, F_b , is based on a fully supported member, properly sheathed and nailed on one edge of the joist.

A.3 Rafters

A.3.1 Rafters with L/240 Deflection Limitations

Tables R-1 through R-12 list spans for rafters with deflection limitations of L/240, used over a single span with calculations based on F_b values and the required E values shown. The allowable bending design value, F_b , is based on a fully supported member, properly sheathed and nailed on the top edge of the rafter. Generally, a deflection limitation of L/240 applies to rafters with a drywall ceiling attached to the underside (e.g., cathedral ceilings).

The maximum moment for a single span beam with a uniform load is defined above. This equation can be rewritten to solve for L as follows:

$$L = \sqrt{\frac{8 F_b S}{w}} \quad [\text{Eq. A.3.1-1}]$$

The uniform load, w, is based on the total dead plus live load and joist spacing.

The required modulus of elasticity, E, is determined based on this calculated span as follows:

$$E = \frac{5wL^3(240)}{384 I} \quad [\text{Eq. A.3.1-2}]$$

The uniform load, w, is based on the live load and joist spacing.

A.3.2 Rafters with L/180 Deflection Limitations

Tables R-13 through R-24 list spans for rafters with deflection limitations of L/180, used over a single span with calculations based on F_b values and the required E values shown. Calculations for span and required modulus of elasticity are the same as those for single span beams with deflection limitations of L/240, except that 180 is substituted for 240 in the numerator of Equation A.3.1-2. Generally, a deflection limitation of L/180 applies to rafters without a drywall ceiling attached to the underside. Some governing building codes also consider the slope of the rafter in determining deflection limitations, and only allow L/180 deflec-

tion limitations for rafters with slopes greater than 3 in 12 and no ceiling attached.

A.3.3 Roof Loads

Section 6 outlines adjustment factors for determining rafter spans and required E values for roof live loads of 12 psf or 16 psf. The tabulated spans are modified by the square root of the ratio of the total uniform load at 20 psf and the total uniform load at the reduced level (12 or 16 psf). This is based on Equation A.3.1-1 which is used to calculate the span of a rafter based on the square root of the total uniform load.

The E values are adjusted based on the modified span as noted above and the uniform live load ratio. Based on Equation A.3.1-2:

$$\frac{E_2}{E_1} = \left(\frac{w_2}{w_1} \right) \left(\frac{L_2}{L_1} \right)^3 \quad [\text{Eq. A.3.3-1}]$$

$$= \left(\frac{LL_2}{LL_1} \right) \left(\frac{LL_1+DL_1}{LL_2+DL_2} \right)^{3/2} \quad [\text{Eq. A.3.3-2}]$$

where subscript 1 denotes variables associated with the 20 psf uniform live load and subscript 2 denotes variables associated with the uniform live load at the reduced level. LL is the uniform live load and DL is the uniform dead load. All other variables are as previously defined in A.3.

A.4 Compression Perpendicular to Grain Design Requirements

Compression perpendicular to grain is also a design consideration for joists and rafters. Required compression perpendicular to grain design values are tabulated in Table 9.1. These values are calculated assuming a bearing width of 1.5", a total load of 66.67 plf, and the calculated span. The 66.67 plf total load is based on a 40 psf live load and 10 psf dead load on joists at 16" on center, which is a typical condition of use. Alternate $F_{c\perp}$ values are possible by adjusting the tabulated values in direct proportion to the desired load. Adjustment factors for various loads and spacings are tabulated in Table 9.2 for convenience. Required compression design values perpendicular to grain are also applicable to bearing plates.

A.5 Lumber Design Values

The spans for nominal 2x5 joists or rafters are 82 percent of the spans tabulated for the same spacing of nominal 2x6 joists or rafters. For each joist or rafter spacing, the values of E for 2x5's are the same as the tabulated E values for 2x6's. The values of F_b for 2x5's shall be determined by multiplying the tabulated F_b values for 2x6's by 1.077.

A.6 Load Requirements

Applicable design criteria for each condition of use appear at the top of each table. While these criteria are directed principally to residential construction they are suitable for other occupancies having similar conditions of loading. Examples include, but are not limited to, assembly areas with fixed seats, cornices, fire escapes for single family residential buildings, cell blocks of penal institutions, multiple family dwelling units and hotel guest rooms. Check governing building code requirements for other applicable occupancies. Tabulated spans for rafters also apply to other types of occupancy, since the occupancy has little bearing on roof loading.

The live and dead load requirements are based on various common loading conditions. The following tables (Tables A-1, A-2, A-3, and A-4) are intended to provide guidance regarding the type of material or occupancy that might create the loads in each span table. Tables A-1, A-2, A-3, and A-4 are intended as a guide only and are superseded by the governing building code in the applicable jurisdiction.

A.7 Support Requirements

Adequate support shall be provided for all joists and rafters. Ridge beams shall be installed at roof peaks, and rafters shall bear directly on the ridge beam or be supported by hangers or framing anchors. Ceiling joists shall not be required when properly designed ridge beams are used.

A ridge board shall be permitted to be substituted for a ridge beam when the roof slope equals or exceeds 3 in 12, except that ridge beams shall be required for cathedral ceilings. Ridge boards shall be at least 1 inch nominal in thickness and not less than the depth of the cut end of the rafter. Rafters shall be placed directly opposite each other, and ceiling joists shall be installed parallel with rafters to provide a continuous tie between exterior walls.

A.8 Repetitive Member Use

Repetitive member use is that condition where framing members such as joists, rafters, studs, planks, decking, or similar members are in contact or spaced not more than 24 inches on-center, are not less than 3 in number, and are joined by floor, roof, or other load-distributing elements adequate to support the design load. Bending design values (F_b) for such use are 15 percent greater than for single-member use. Tables W-1 and W-2 of *Design Values for Joists and Rafters*, a supplement to these tables, provide bending design values for repetitive member use of joists and rafters.

A.9 Load Duration

For joists and rafters, bending design values (F_b) are adjusted for load duration by the following factors:

1.00 for 10 years (normal) duration, as for occupancy live load,

1.15 for 2 months duration, as for snow,

1.25 for 7 days duration, as for construction loading.

Tables W-1 and W-2 of *Design Values for Joists and Rafters*, a supplement to these tables, provide bending design values for repetitive member use of joists and rafters under 10 years (normal), 2 months, and 7 days load duration.

A.10 Use of the Span Tables

Spans for floor and ceiling joists are calculated on the basis of the modulus of elasticity (E) with the required bending design value (F_b) listed below each span. Spans for rafters are calculated on the basis of bending design values (F_b) with the required modulus of elasticity (E) listed below each span. Required compression perpendicular to grain design values ($F_{c\perp}$) are tabulated based on span and bearing length with adjustments for different loading and on-center spacings. Use of the tables is illustrated in the examples which follow. Values determined from the span tables should be compared to values from Tables W-1 and W-2 of *Design Values for Joists and Rafters*. Species and grades with design values greater than or equal to those shown in the span tables are appropriate.

Table A-1. FLOOR JOISTS WITH L/360 DEFLECTION LIMITATIONS

Table No.	Live Load (psf)	Dead ¹ Load (psf)	Material or Occupancy
F-1	30	10	All rooms used for sleeping areas and attic floors
F-2	40	10	Decks and all rooms except those used for sleeping areas and attic floors
F-3	50	10	Office space (concentrated load checks may be required)
F-4	60	10	Decks or corridors
F-5	40	20	All rooms, except those used for sleeping areas and attic floors, with 1.5" or less lightweight concrete floor fill
F-6	50	20	Office space (concentrated load checks may be required) with 1.5" or less lightweight concrete floor fill
F-7	60	20	Decks or corridors with 1.5" or less lightweight concrete floor fill

1. Dead load includes the weight of the framing members.

Table A-2. CEILING JOISTS WITH L/240 DEFLECTION LIMITATIONS

Table No.	Live Load (psf)	Dead ¹ Load (psf)	Material or Occupancy
C-1	10	5	Drywall ceiling attached, no attic storage
C-2	20	10	Drywall ceiling attached, limited attic storage where development of future rooms is not possible

1. Dead load includes the weight of the framing members.

Example 1. Floor Joists

Assume a required single span of 12'-9", a live load of 40 psf, dead load of 10 psf and joists spaced 16 inches on centers. Table F-2 shows that a grade of 2x8 having an E value of 1,600,000 psi and an F_b value of 1255 psi would have a span of 12'-10", which satisfies the condition. Assuming a 2" bearing length, Table 9.1 shows 156 psi for $F_{c\perp}$ at a 14' span. Table 9.2 shows an adjustment factor of 1.0. The grade of 2x8 would also need an $F_{c\perp}$ value greater than 156 psi.

Example 2. Rafters

Assume a horizontal projection span of 13'-0", a live load of 20 psf, dead load of 10 psf, L/240 deflection limitation and rafters spaced 16 inches on centers. Table R-1 shows that a 2x6 having an F_b value of 1400 psi and an E value of 1,350,000 psi would have a span of 13'-3" of horizontal projection. Conversion of horizontal to sloping distance is illustrated on page A-7. Table 9.1 shows a required $F_{c\perp}$ value of 89 psi assuming a 3.5" bearing length. Table 9.2 allows that to be adjusted by a factor of 0.60, which equals 53 psi. The grade of 2x6 would need an $F_{c\perp}$ value greater than 53 psi.

**Table A-3. RAFTERS WITH L/240 DEFLECTION LIMITATIONS
(Drywall ceiling attached to underside of rafter)**

Table No.	Live Load (psf)	Dead¹ Load (psf)	Material or Occupancy
R-1	20	10	Light roof (1 course of asphalt shingles)
R-2	30	10	Light roof (1 course of asphalt shingles)
R-3	40	10	Light roof (1 course of asphalt shingles)
R-4	50	10	Light roof (1 course of asphalt shingles)
R-5	20	15	Medium roof covering (up to 2 courses of asphalt shingles, or wood shakes/shingles)
R-6	30	15	Medium roof covering (up to 2 courses of asphalt shingles, or wood shakes/shingles)
R-7	40	15	Medium roof covering (up to 2 courses of asphalt shingles, or wood shakes/shingles)
R-8	50	15	Medium roof covering (up to 2 courses of asphalt shingles, or wood shakes/shingles)
R-9	20	20	Heavy roof covering (2" clay book tile)
R-10	30	20	Heavy roof covering (2" clay book tile)
R-11	40	20	Heavy roof covering (2" clay book tile)
R-12	50	20	Heavy roof covering (2" clay book tile)

1. Dead load includes the weight of the framing members, wood structural panels, gypsum, and insulation.

**Table A-4. RAFTERS WITH L/180 DEFLECTION LIMITATIONS
(No drywall ceiling attached to underside of rafter)**

Table No.	Live Load (psf)	Dead¹ Load (psf)	Material or Occupancy
R-13	20	10	Light roof (up to 2 courses of asphalt shingles, or wood shakes/shingles)
R-14	30	10	Light roof (up to 2 courses of asphalt shingles, or wood shakes/shingles)
R-15	40	10	Light roof (up to 2 courses of asphalt shingles, or wood shakes/shingles)
R-16	50	10	Light roof (up to 2 courses of asphalt shingles, or wood shakes/shingles)
R-17	20	15	Medium roof covering (up to 1/4" slate)
R-18	30	15	Medium roof covering (up to 1/4" slate)
R-19	40	15	Medium roof covering (up to 1/4" slate)
R-20	50	15	Medium roof covering (up to 1/4" slate)
R-21	20	20	Heavy roof covering (2" clay book tile)
R-22	30	20	Heavy roof covering (2" clay book tile)
R-23	40	20	Heavy roof covering (2" clay book tile)
R-24	50	20	Heavy roof covering (2" clay book tile)

1. Dead load includes the weight of the framing members and wood structural panels.

Example 3. Two-span Floor Joists. Assume two floor systems are required to span 12' rooms on either side of a 6' corridor. The rooms require a 40 psf live load and the corridor requires an 80 psf live load. All spans require a 10 psf dead load. Table F-2 shows a 2x12 at 16" on-center with $E=1,200,000$ psi and $F_b=1036$ psi will span 18'-1". By overlapping these joists across the corridor, as shown in Figure A.10-1, a spacing of 8" on-center will be achieved on the corridor, which effectively carries twice the live load. This provides adequate support for the required 80 psf live load across the corridor.

Table 9.1 shows a required $F_{c\perp}$ value of 114 psi assuming a 3.5" bearing length. Doubling this value in accordance with A.1.3 gives 228. Table 9.2 shows an adjustment factor of 1.0. The grade of 2x12 would need an $F_{c\perp}$ value greater than 228 psi.

Since many combinations of size, spacing, E , F_b , and $F_{c\perp}$ values are possible, the user should examine the tables to determine which combination fits the particular case most effectively.

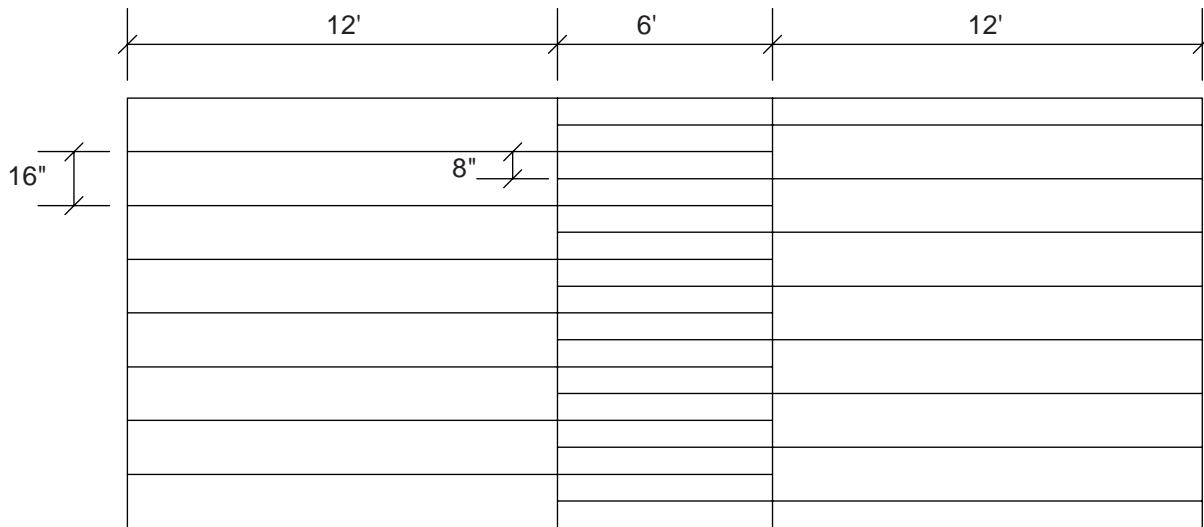
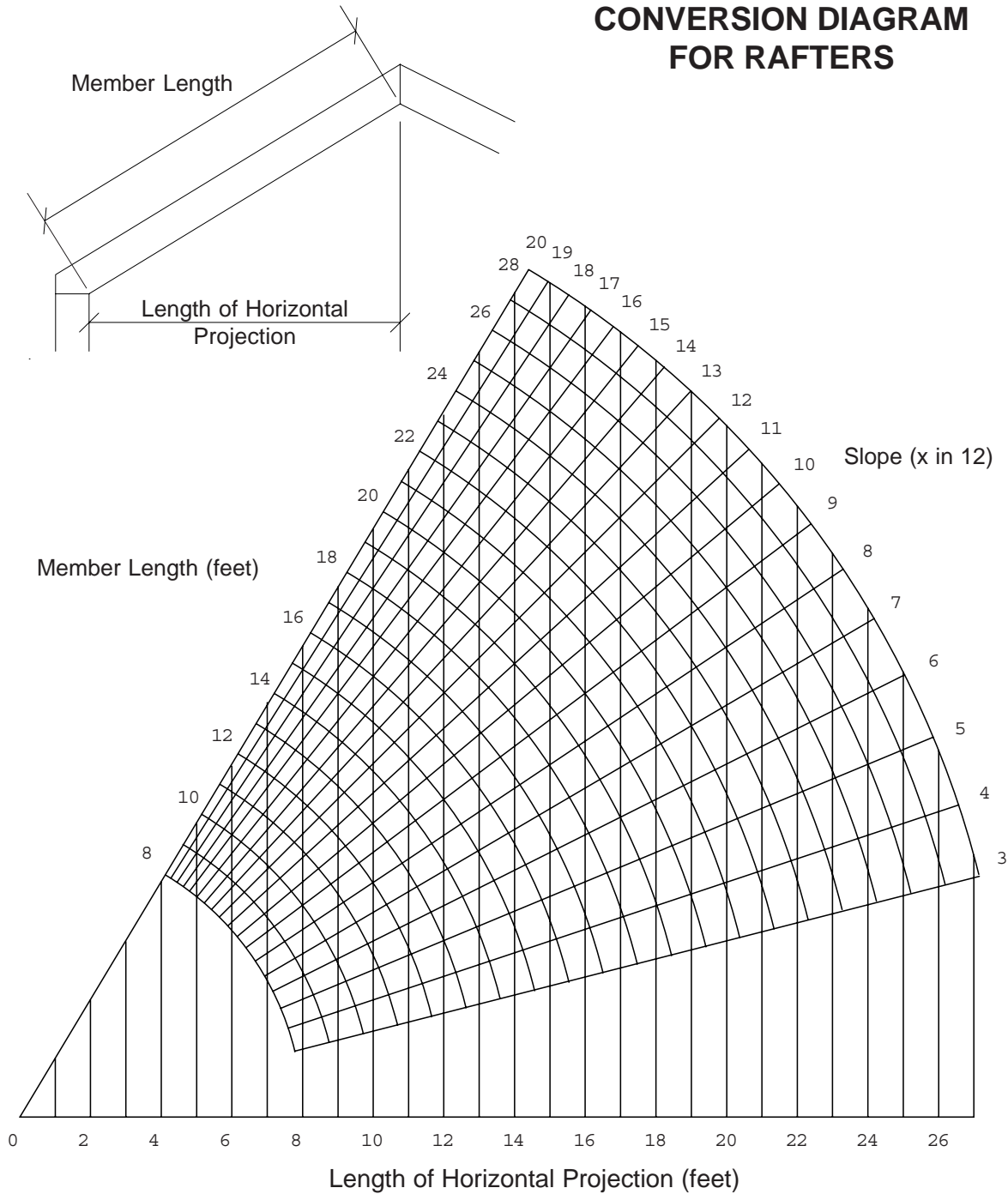

Figure A.10-1 Two-span floor joists overlap at interior span to double load-carrying capacity of the floor system for the corridor.

CONVERSION DIAGRAM FOR RAFTERS



To use the diagram, select the known horizontal distance and follow the vertical line to its intersection with the radial line of the specified slope, then proceed along the arc to read the sloping distance. Interpolation is appropriate between the one foot increments. The diagram also gives the horizontal distance

corresponding to a given sloping distance or the slope when the horizontal and sloping distances are known.

Example: With a roof slope of 8 in 12 and a horizontal distance of 20 feet the sloping distance is read as 24 feet.

**American Forest & Paper Association
American Wood Council
1111 19th Street, NW
Suite 800
Washington, DC 20036
Phone: 202-463-4713
Fax: 202-463-2791
awcinfo@afandpa.org
www.awc.org**

A F & P A[®]

