

CONCRETE MASONRY CURTAIN AND PANEL WALL DETAILS

TEK 5-6A
Details (2001)

Keywords: architectural details, construction details, curtain walls, high rise construction, nonbearing walls, panel walls, wall movement, veneer

INTRODUCTION

Steel and concrete structural frames often rely on nonload-bearing masonry curtain or panel walls to enclose the structure. Panel and curtain walls are distinguished by the fact that a panel wall is wholly supported at each story, while a curtain wall is supported only at its base, or at prescribed interims. Both are designed to resist lateral wind or seismic loads and transfer these lateral loads to the structural frame. They typically do not carry any vertical loads other than their own weight. Curtain and panel walls differ from anchored masonry veneer in that veneer is continuously supported by a backup material.

Curtain and panel walls must be isolated from the frame to prevent the unintentional transfer of structural loads and to allow differential movement between the frame and the masonry. Anchorage between the concrete masonry and structural frame must also account for different construction tolerances for each building material.

Concrete masonry curtain and panel walls should incorporate flashing and weep holes as for other concrete masonry construction. *Design for Dry Single-Wythe Concrete Masonry Walls, Flashing Strategies for Concrete Masonry Walls and Flashing Details for Concrete Masonry Walls* (refs. 3, 4 & 5) provide detailed information.

PANEL WALLS

Concrete masonry panel walls are supported at each building story by means of concrete beams, concrete slabs or steel members.

Supports must take into account the strains and deformations in both the concrete masonry panel wall and the structural frame. Steel supports, often in the form of shelf angles, can be attached to the frame either by welding or bolting, although bolting is often preferred because slotted bolt holes permit adjustments to be made for proper alignment with the masonry. In addition, bolted connections are inherently more flexible than welded connections, allowing a limited amount of movement between the masonry and the frame. Care should be taken,

however, to ensure proper bolt tension to avoid slipping once positioned.

For high-rise construction, allowance should be made for differential movement between the shelf angle and the panel wall below due to creep of the frame and/or masonry thermal expansion. This is accomplished by leaving an open (mortarless) space between the bottom of the shelf angle and the masonry below or by filling the space with compressible

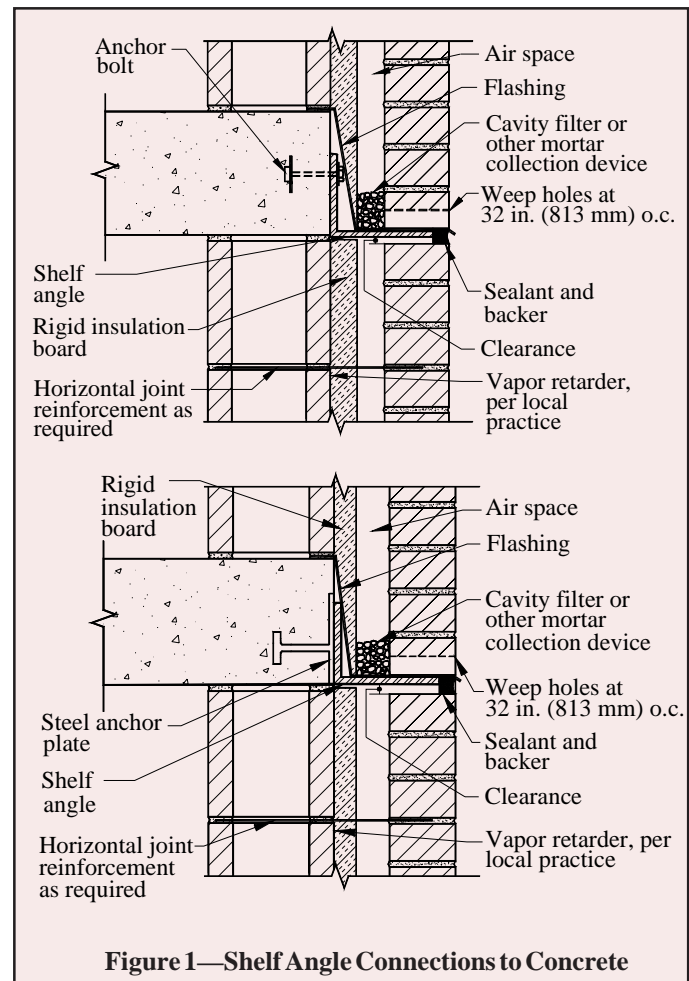

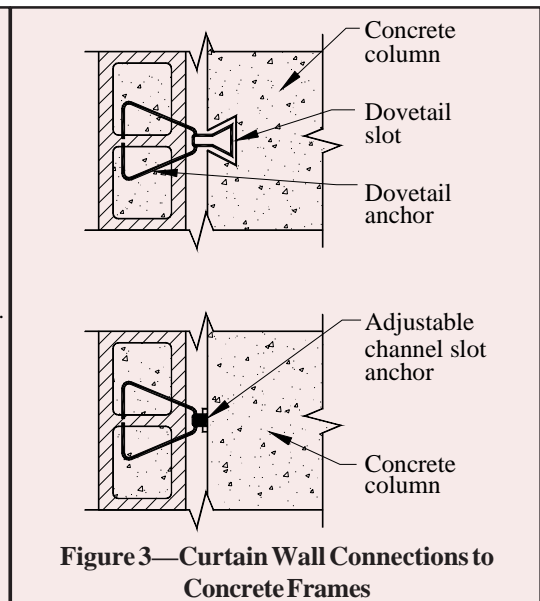
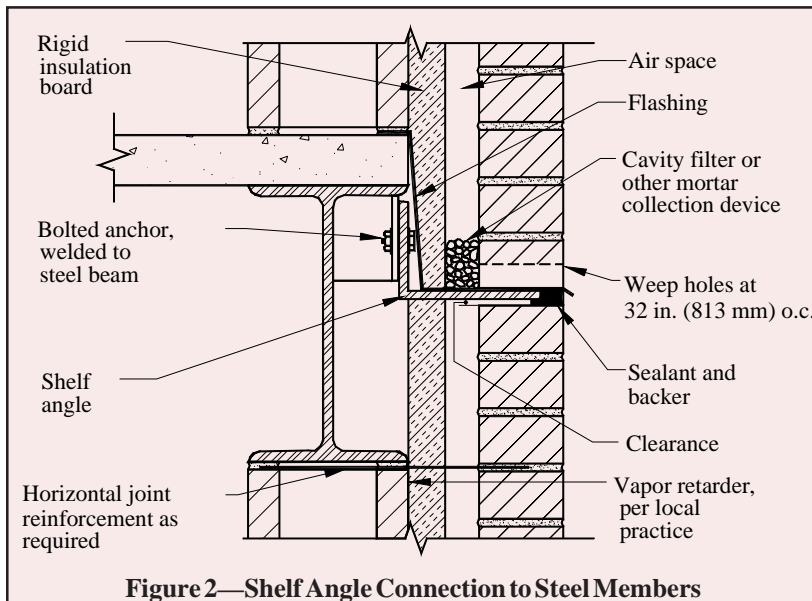

material. The joint is then sealed with caulking to prevent moisture intrusion. The horizontal movement joint below the shelf angle also helps prevent vertical loads from inadvertently being transferred to the concrete masonry panel wall below the shelf angle.

Flashing and weep holes should be installed immediately above all shelf angles to drain moisture. In multi-wythe panel walls, wall ties between the exterior and interior masonry wythes should be located as close to the shelf angle as possible. Figures 1 and 2 show steel shelf angle attachments to concrete and steel, respectively.

CURTAIN WALLS

Concrete masonry curtain walls can be designed to span either vertically or horizontally between supports. They can also incorporate reinforcement to increase lateral load resistance and the required distance between lateral supports.

Anchors used to provide lateral support must be sufficiently stiff in the out-of-plane direction to transfer lateral loads to the frame and be flexible enough in-plane to allow differential movement between the curtain wall and the frame. In addition, *Building Code Requirements for Masonry Structures* (ref. 1) includes specific corrosion-resistance requirements to ensure long-term integrity of the anchors, consisting of AISI Type 304 stainless steel or galvanized or epoxy coatings.

Anchors are required to be embedded at least 1½ in. (38.1 mm) into the mortar bed when solid masonry units are used (ref. 1) to prevent failure due to mortar pullout or pushout. Because of the magnitude of anchor loads, it is also recommended that they be embedded in filled cores when using hollow units. As an alternative to completely filling the masonry core, this can be accomplished by placing a screen under the anchor and building up 1 to 2 in. (25 to 51 mm) of mortar into the core of the block above the anchor.

For both concrete and steel frames, the space between the column and the masonry should be kept clear of mortar to avoid rigidly bonding the two elements together.

Figures 3 through 5 show curtain wall attachments to concrete and steel frames.

CONSTRUCTION TOLERANCES

Tolerances are allowable variations, either in individual component dimensions or in building elements such as walls or roofs. Construction tolerances recognize that building elements cannot always be placed exactly as specified, but establish limits on how far they can vary to help ensure the finished building will function as designed.

When using masonry with another structural system, such as steel or concrete, construction tolerances for each material need to be accommodated, since construction tolerances vary for different building materials.

In general, masonry must be constructed to tighter tolerances than those applicable to steel or concrete frames (refs. 2, 7). Particularly in high-rise buildings, tolerances can potentially affect anchor embedment, flashing details and available support at the shelf angle. To help accommodate these variations in the field, the following recommendations should be considered.

- Use bolted connections with slotted holes for steel shelf angles to allow the shelf angle location to be adjusted to meet field conditions. Steel shims can be used to make horizontal adjustments to the shelf angle location. Figure 6 shows an example of a shelf angle connection which is adjustable in all three directions. For connections like this, the bottom flange needs to be evaluated for adequate load carrying capability as does the beam for torsion.
- When shimming shelf angles, use shims that are the full height of the vertical leg of the shelf angle for stability. Shimming is limited to a maximum of 1 in. (25 mm) (ref. 7).
- Provide a variety of anchor lengths to allow proper embedment over the range of construction tolerances.
- Use two-piece flashing to accommodate varying cavity widths.
- Cut masonry units only with the permission of the architect or engineer (this may be proposed when the frame cant

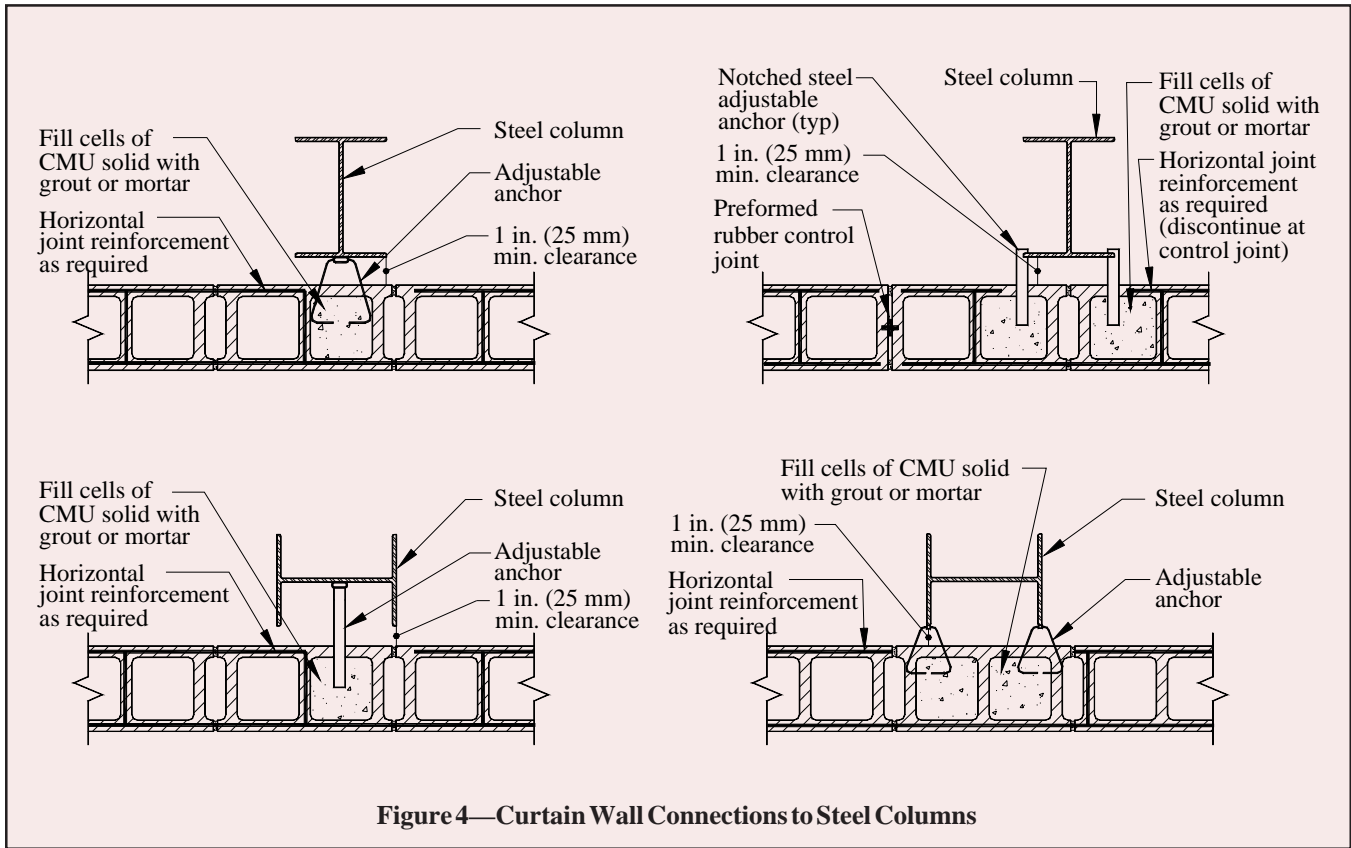

Figure 4—Curtain Wall Connections to Steel Columns

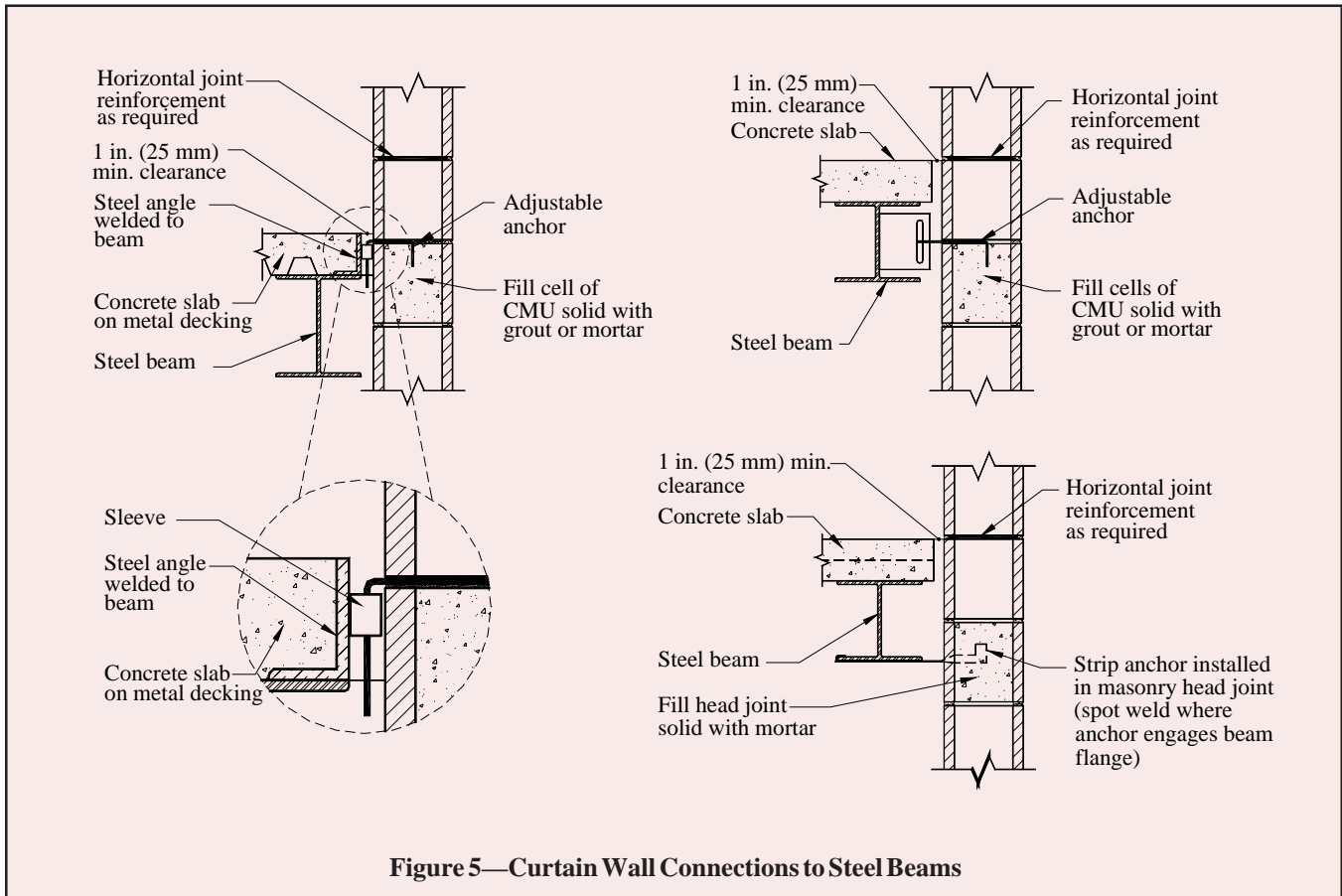
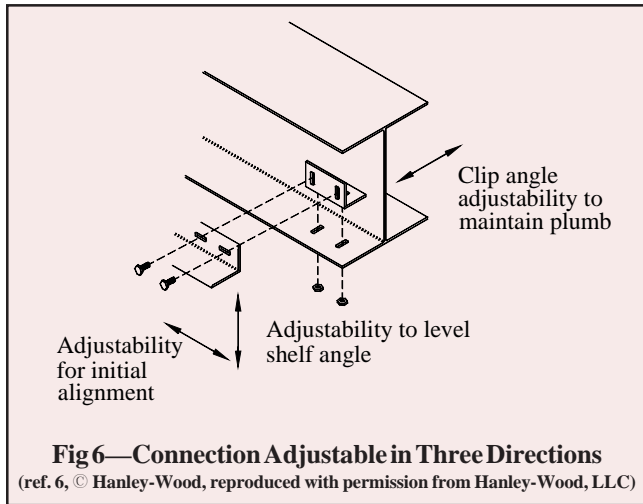

Figure 5—Curtain Wall Connections to Steel Beams

towards the masonry, making the cavity between the two materials too small).

- Include instructions for handling building element misalignment in the construction documents.



REFERENCES

1. *Building Code Requirements for Masonry Structures*, ACI 530-99/ASCE 5-99/TMS 402-99. Reported by the Masonry Standards Joint Committee, 1999.
2. *Specification for Masonry Structures*, ACI 530.1-99/ASCE 6-99/TMS 602-99. Reported by the Masonry Standards Joint Committee, 1999.
3. *Design for Dry Single-Wythe Concrete Masonry Walls*, TEK 19-2A. National Concrete Masonry Association, 2001.
4. *Flashing Strategies for Concrete Masonry Walls*, TEK 19-4A. National Concrete Masonry Association, 2001.
5. *Flashing Details for Concrete Masonry Walls*, TEK 19-5A. National Concrete Masonry Association, 2000.
6. Laska, W. *Masonry and Steel Detailing Handbook*. The Aberdeen Group, 1993.
7. *Code of Standard Practice for Steel Buildings and Bridges*, American Institute of Steel Construction, Inc., 2000.

Provided by:
Cinder & Concrete Block Corporation

Disclaimer: NCMA and the companies disseminating this technical information disclaim any and all responsibility and liability for the accuracy and the application of the information contained in this publication.

NATIONAL CONCRETE MASONRY ASSOCIATION
2302 Horse Pen Road, Herndon, Virginia 20171-3499
www.ncma.org

To order a complete TEK Manual or TEK Index,
contact NCMA Publications (703) 713-1900