

National Concrete Masonry Association
an information series from the national authority on concrete masonry technology

ALLOWABLE STRESS DESIGN OF CONCRETE MASONRY FOUNDATION WALLS

TEK 15-1B

Structural (2001)

Keywords: allowable stress design, basements, basement walls, empirical design, flexural strength, lateral loads, reinforced concrete masonry, structural properties

INTRODUCTION

Basements provide: economical living, working and storage areas; convenient spaces for mechanical equipment; safe havens during tornadoes and other violent storms; and easy access to plumbing and ductwork. Concrete masonry is well suited to basement and foundation wall construction due to its inherent durability, compressive strength, economy, and resistance to fire, termites, and noise.

Traditionally, residential basement walls have been constructed of plain (unreinforced) concrete masonry, often designed empirically. Walls over 8 ft (2.4 m) high or with larger soil loads are typically designed using reinforced concrete masonry or using design tables included in building codes such as the *International Building Code* (ref. 4).

DESIGN LOADS

Soil imparts a lateral load on foundation walls. For design, the load is traditionally assumed to increase linearly with depth resulting in a triangular load distribution. This lateral soil load is expressed as an equivalent fluid pressure, with units of pounds per square foot per foot of depth (kPa/m). The maximum force on the wall depends on the total wall height, soil backfill height, wall support conditions, soil type, and the existence of any soil surcharges. For design, foundation walls are typically assumed to act as simple vertical beams laterally supported at the top and bottom.

Foundation walls also provide support for the structure above, transferring vertical loads to the footing. When foundations span vertically, this vertical compression counteracts flexural tension, increasing the wall's resistance to flexure. In low-rise construction, these vertical loads are typically small in relation to the compressive strength of concrete masonry. Further, if the wall spans horizontally, vertical compression does not offset the flexural tension. Vertical load effects are not included in the tables and design example presented in this TEK (references 2 and 3 include vertical load effects).

EMPIRICAL DESIGN

The empirical design method uses historical experience

to proportion and size masonry elements. Empirical design is often used to design concrete masonry foundation walls due to its simplicity and history of successful performance.

Table 1 lists the allowable backfill heights for 8, 10 and 12-inch (203, 254 and 305 mm) concrete masonry foundation walls. Table 1 may be used for foundation walls up to 8 feet (2.4 m) high under the following conditions (ref. 1):

- (1) terrain surrounding the foundation wall is graded to drain surface water away from foundation walls,
- (2) backfill is drained to remove ground water away from foundation walls,
- (3) tops of foundation walls are laterally supported prior to backfilling,
- (4) the length of foundation walls between perpendicular masonry walls or pilasters is a maximum of 3 times the foundation wall height,
- (5) the backfill is granular and soil conditions in the area are non-expansive,
- (6) masonry is laid in running bond using Type M or S mortar, and
- (7) units meet the requirements of ASTM C 90 (ref. 6).

Where these conditions cannot be met, the wall must be engineered using either an allowable stress design (see following section) or strength design procedure (see ref. 5).

Table 1—Empirical Foundation Wall Design (ref. 1)^a

Wall construction	Nominal wall thickness, in. (mm)	Maximum depth of unbalanced backfill ^b , ft (m)
Hollow unit masonry	8 (203)	5(1.52)
	10 (254)	6(1.83)
	12 (305)	7(2.13)
Solid unit masonry	8 (203)	5(1.52)
	10 (254)	7(2.13)
	12 (305)	7(2.13)
Fully grouted masonry	8 (203)	7(2.13)
	10 (254)	8(2.44)
	12 (305)	8(2.4)

^a see notes above for conditions

^b unbalanced backfill is the distance from the top of the basement floor slab to the top of the backfill

WALL DESIGN

Tables 2 through 4 of this TEK have been rationally designed in accordance with the allowable stress design provisions of *Building Code Requirements for Masonry Structures* (ref. 1) and therefore meet the requirements of the *International Building Code* even though the latter limits reinforcement spacing to 72 in. (1829 mm) when using their tables. Additional reinforcement alternatives may be appropriate and can be verified with an engineering analysis.

Tables 2, 3 and 4 list reinforcement options for 8, 10 and 12-in. (203, 254 and 305-mm) thick walls, respectively. The effective depths of reinforcement, d , (see Table notes) used are practical values, taking into account variations in face shell thickness, a range of bar sizes, minimum required grout cover, and construction tolerances for placing the reinforcing bars.

Tables 2 through 4 are based on the following:

- (1) no surcharges on the soil adjacent to the wall and no hydrostatic pressure,
- (2) negligible axial loads on the wall,
- (3) wall is simply supported at top and bottom,
- (4) wall is grouted only at reinforced cells,
- (5) section properties are based on minimum face shell and web thicknesses in ASTM C 90 (ref. 6),
- (6) specified compressive strength of masonry, f'_m , is 1,500 psi (10.3 MPa),
- (7) reinforcement yield strength, f_y , is 60,000 psi (414 MPa),
- (8) modulus of elasticity of masonry, E_m , is 1,350,000 psi (9,308 MPa),
- (9) modulus of elasticity of steel, E_s , is 29,000,000 psi (200,000 MPa),
- (10) maximum width of compression zone is six times the wall thickness (where reinforcement spacing exceeds this distance, the ability of the plain masonry outside the compression zone to distribute loads horizontally to the reinforced section was verified assuming two-way plate action),
- (11) allowable tensile stress in reinforcement, F_s , is 24,000 psi (165 MPa),
- (12) allowable compressive stress in masonry, F_b , is $1/3 f'_m$ (500 psi, 3.4 MPa),
- (13) grout complies with ASTM C 476 (2,000 psi (14 MPa) if property spec is used) (ref. 7), and
- (14) masonry is laid in running bond using Type M or S mortar and face shell mortar bedding.

DESIGN EXAMPLE

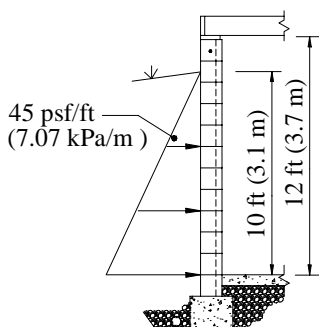

Wall: 12-inch (305 mm) thick, 12 feet (3.7 m) high.

Loads: equivalent fluid pressure of soil is 45 pcf (7.07 kPa/m), 10 foot (3.1 m) backfill height. No axial, seismic, or other loads.

Using Table 4, #8 bars at 40 in. (M 25 at 1016 mm) o.c. are sufficient.

Table 2—Vertical Reinforcement for 8 in. (203 mm) Concrete Masonry Foundation Walls^{a, b}

Wall height, ft (m)	Backfill height, ft (m)	Reinforcement size (No.) and spacing (in. o.c.) required for equivalent fluid pressure of soil, psf/ft depth (kPa/m):		
		30 (4.71) ^c	45 (7.07) ^d	60 (9.43) ^e
7.3 (2.2)	4 (1.2)	5 @ 120 in.	6 @ 120 in.	5 @ 72 in.
	5 (1.5)	5 @ 72 in.	4 @ 40 in.	5 @ 40 in.
	6 (1.8)	4 @ 40 in.	5 @ 40 in.	6 @ 40 in.
	7 (2.1)	5 @ 40 in.	6 @ 40 in.	8 @ 48 in.
8 (2.4)	4 (1.2)	5 @ 120 in.	5 @ 96 in.	7 @ 120 in. ^h
	5 (1.5)	5 @ 72 in. or 6 @ 120 in. ^h	4 @ 32 in. or 8 @ 120 in. ^h	5 @ 40 in. or 7 @ 72 in. ^h
	6 (1.8)	4 @ 32 in. or 6 @ 72 in. ^h or 7 @ 96 in. ^h	5 @ 32 in. or 6 @ 48 in. or 7 @ 72 in. ^h	5 @ 24 in. or 6 @ 40 in. or 8 @ 56 in. ^h
	7 (2.1)	5 @ 40 in. or 6 @ 56 in. ^h or 7 @ 72 in. ^h	5 @ 24 in. or 6 @ 32 in. or 8 @ 56 in. ^h	6 @ 24 in. or 7 @ 32 in. or 8 @ 48 in.
	8 (2.4)	5 @ 24 in. or 7 @ 64 in. ^h	6 @ 24 in. or 8 @ 48 in.	5 @ 8 in.
9.3(2.8)	4 (1.2)	4 @ 96 in. or 5 @ 120 in.	5 @ 96 in. or 6 @ 120 in.	5 @ 72 in. or 7 @ 120 in. ^h
	5 (1.5)	5 @ 72 in. or 7 @ 120 in. ^h	5 @ 48 in. or 8 @ 120 in. ^h	5 @ 40 in. or 7 @ 72 in. ^h
	6 (1.8)	5 @ 48 in. or 7 @ 96 in. ^h	5 @ 32 in. or 8 @ 72 in. ^h	5 @ 24 in. or 8 @ 56 in. ^h
	7 (2.1)	5 @ 32 in. or 8 @ 72 in. ^h	5 @ 24 in. or 8 @ 56 in. ^h	4 @ 8 in. or 7 @ 24 in.
	8 (2.4)	6 @ 32 in. or 8 @ 56 in. ^h	4 @ 8 in. or 7 @ 24 in.	7 @ 8 in.
10(3.1)	9 (2.7)	6 @ 24 in. or 8 @ 48 in.	6 @ 8 in.	8 @ 8 in.
	4 (1.2)	4 @ 72 in. or 5 @ 120 in.	5 @ 72 in. or 6 @ 120 in.	5 @ 64 in. or 7 @ 120 in. ^h
	5 (1.5)	5 @ 72 in. or 7 @ 120 in. ^h	5 @ 48 in. or 8 @ 120 in. ^h	5 @ 32 in. or 7 @ 72 in. ^h
	6 (1.8)	5 @ 48 in. or 7 @ 96 in. ^h	5 @ 32 in. or 8 @ 72 in. ^h	6 @ 32 in. or 8 @ 56 in. ^h
	7 (2.1)	5 @ 32 in. or 8 @ 72 in. ^h	6 @ 24 in. or 8 @ 48 in.	5 @ 8 in. or 8 @ 24 in.
	8 (2.4)	5 @ 24 in. or 8 @ 56 in. ^h	5 @ 8 in. or 8 @ 24 in.	8 @ 8 in.
	9 (2.7)	6 @ 24 in. or 8 @ 40 in.	7 @ 8 in.	—

Notes to Tables 2, 3, and 4:

^a effective depth of reinforcement (distance from extreme compression fiber to centroid of tension reinforcement), d , is 4 ⁵/₈ in. (117 mm) minimum

^b metric equivalents: 1 in. (25.4 mm); No. 4 bar (M 13); No. 5 (M 16); No. 6 (M 19); No. 7 (M 22); No. 8 (M 25)

^c granular soil backfill

^d drained silty sand or clayey silt backfill

^e clay soil (non-expansive) backfill

^f effective depth of reinforcement d , is 6 ⁵/₈ in. (168 mm) minimum

^g effective depth of reinforcement d , is 8 ⁵/₈ in. (219 mm) minimum

^h use Portland cement/lime or mortar cement mortar (Type M or S)

Table 3—Vertical Reinforcement for 10 in. (254 mm) Concrete Masonry Foundation Walls^{b, f}

Wall height, ft (m)	Backfill height, ft (m)	Reinforcement size (No.) and spacing (in. o.c.) required for equivalent fluid pressure of soil, psf/ft depth (kPa/m):		
		30 (4.71) ^c	45 (7.07) ^d	60 (9.43) ^e
7.3 (2.2)	4 (1.2)	No reinforcement	5 @ 120 in.	5 @ 96 in.
	5 (1.5)	4 @ 72 in. or 5 @ 120 in.	5 @ 72 in. or 6 @ 120 in. ^h	5 @ 64 in. or 7 @ 120 in. ^h
	6 (1.8)	5 @ 72 in. or 6 @ 120 in. ^h	5 @ 56 in. or 7 @ 96 in. ^h	5 @ 40 in. or 7 @ 72 in. ^h
	7 (2.1)	4 @ 40 in. or 7 @ 96 in. ^h	5 @ 40 in. or 6 @ 72 in. ^h	5 @ 32 in. or 7 @ 56 in. ^h
8 (2.4)	4 (1.2)	No reinforcement	5 @ 120 in.	5 @ 96 in.
	5 (1.5)	5 @ 120 in.	5 @ 72 in.	5 @ 64 in.
	6 (1.8)	5 @ 72 in. or 6 @ 120 in. ^h	5 @ 56 in. or 7 @ 96 in. ^h	5 @ 40 in. or 7 @ 72 in. ^h
	7 (2.1)	5 @ 56 in. or 6 @ 72 in. ^h or 7 @ 96 in. ^h	5 @ 40 in. or 6 @ 56 in. or 7 @ 72 in. ^h	5 @ 24 in. or 6 @ 40 in. or 7 @ 56 in.
	8 (2.4)	5 @ 40 in. or 7 @ 72 in. ^h	5 @ 24 in. or 8 @ 64 in. ^h	6 @ 32 in. or 8 @ 56 in.
9.3(2.8)	4 (1.2)	No reinforcement	5 @ 120 in.	5 @ 96 in.
	5 (1.5)	4 @ 72 in. or 5 @ 120 in.	5 @ 72 in. or 7 @ 120 in. ^h	5 @ 56 in. or 8 @ 120 in. ^h
	6 (1.8)	5 @ 72 in. or 7 @ 120 in. ^h	5 @ 48 in. or 7 @ 96 in. ^h	5 @ 32 in. or 7 @ 72 in. ^h
	7 (2.1)	5 @ 48 in. or 7 @ 96 in. ^h	5 @ 32 in. or 8 @ 72 in. ^h	5 @ 24 in. or 8 @ 56 in.
	8 (2.4)	5 @ 40 in. or 7 @ 72 in. ^h	5 @ 24 in. or 8 @ 64 in. ^h	6 @ 24 in. or 8 @ 48 in.
	9 (2.7)	5 @ 24 in. or 7 @ 56 in. ^h	6 @ 24 in. or 8 @ 48 in.	4 @ 8 in. or 8 @ 32 in.
10(3.1)	4 (1.2)	No reinforcement	5 @ 120 in.	5 @ 96 in.
	5 (1.5)	5 @ 96 in.	5 @ 72 in.	5 @ 56 in.
	6 (1.8)	5 @ 72 in. or 7 @ 120 in. ^h	5 @ 48 in. or 8 @ 96 in. ^h	5 @ 32 in. or 8 @ 72 in. ^h
	7 (2.1)	5 @ 48 in. or 7 @ 96 in. ^h	5 @ 32 in. or 8 @ 72 in. ^h	5 @ 24 in. or 8 @ 56 in.
	8 (2.4)	5 @ 32 in. or 7 @ 72 in. ^h	5 @ 24 in. or 8 @ 56 in.	4 @ 8 in. or 8 @ 40 in.
	9 (2.7)	5 @ 24 in. or 7 @ 56 in.	6 @ 24 in. or 8 @ 48 in.	4 @ 8 in.
	10(3.1)	6 @ 32 in. or 8 @ 56 in.	4 @ 8 in. or 8 @ 32 in.	6 @ 8 in.
12(3.7)	4 (1.2)	No reinforcement	5 @ 120 in.	5 @ 96 in.
	5 (1.5)	5 @ 96 in.	5 @ 72 in.	5 @ 48 in.
	6 (1.8)	5 @ 64 in. or 7 @ 120 in. ^h	5 @ 40 in. or 8 @ 96 in.	5 @ 32 in. or 8 @ 72 in. ^h
	7 (2.1)	5 @ 40 in. or 8 @ 96 in. ^h	5 @ 24 in. or 8 @ 72 in. ^h	6 @ 24 in. or 8 @ 56 in.
	8 (2.4)	5 @ 32 in. or 8 @ 72 in. ^h	6 @ 24 in. or 8 @ 48 in.	4 @ 8 in. or 8 @ 40 in.
	9 (2.7)	5 @ 24 in. or 8 @ 56 in.	4 @ 8 in. or 8 @ 40 in.	5 @ 8 in.
	10(3.1)	8 @ 48 in.	5 @ 8 in.	8 @ 8 in.
	11(3.4)	8 @ 40 in.	7 @ 8 in.	—

Table 4—Vertical Reinforcement for 12 in. (305 mm) Concrete Masonry Foundation Walls^{b, g}

Wall height, ft (m)	Backfill height, ft (m)	Reinforcement size (No.) and spacing (in. o.c.) required for equivalent fluid pressure of soil, psf/ft depth (kPa/m):		
		30 (4.71) ^c	45 (7.07) ^d	60 (9.43) ^e
7.3 (2.2)	4 (1.2)	No reinforcement	No reinforcement	5 @ 120 in.
	5 (1.5)	5 @ 120 in.	5 @ 120 in.	5 @ 72 in.
	6 (1.8)	4 @ 72 in. or 5 @ 120 in.	5 @ 72 in. or 7 @ 120 in. ^h	5 @ 56 in. or 7 @ 96 in. ^h
	7 (2.1)	5 @ 72 in. or 6 @ 120 in. ^h	5 @ 56 in. or 7 @ 96 in. ^h	5 @ 40 in. or 7 @ 72 in.
8 (2.4)	4 (1.2)	No reinforcement	No reinforcement	5 @ 120 in.
	5 (1.5)	5 @ 120 in.	5 @ 96 in.	5 @ 72 in.
	6 (1.8)	5 @ 96 in. or 6 @ 120 in.	5 @ 72 in. or 7 @ 120 in. ^h	5 @ 56 in. or 7 @ 96 in. ^h
	7 (2.1)	5 @ 72 in. or 7 @ 120 in. ^h	5 @ 48 in. or 7 @ 96 in. ^h	5 @ 32 in. or 7 @ 72 in.
	8 (2.4)	5 @ 56 in. or 7 @ 96 in. ^h	5 @ 40 in. or 7 @ 72 in.	5 @ 24 in. or 8 @ 72 in.
9.3(2.8)	4 (1.2)	No reinforcement	No reinforcement	5 @ 120 in.
	5 (1.5)	4 @ 96 in. or 5 @ 120 in.	5 @ 96 in. or 6 @ 120 in.	5 @ 72 in. or 7 @ 120 in. ^h
	6 (1.8)	5 @ 96 in. or 6 @ 120 in.	5 @ 64 in. or 7 @ 120 in. ^h	5 @ 48 in. or 7 @ 96 in. ^h
	7 (2.1)	5 @ 64 in. or 7 @ 120 in. ^h	5 @ 40 in. or 8 @ 96 in. ^h	5 @ 32 in. or 8 @ 72 in.
	8 (2.4)	5 @ 48 in. or 7 @ 96 in. ^h	5 @ 32 in. or 8 @ 72 in.	5 @ 24 in. or 8 @ 64 in.
	9 (2.7)	5 @ 40 in. or 7 @ 72 in.	5 @ 24 in. or 8 @ 64 in.	4 @ 8 in. or 8 @ 48 in.
10 (3.1)	4 (1.2)	No reinforcement	5 @ 120 in.	5 @ 120 in.
	5 (1.5)	5 @ 120 in.	5 @ 96 in.	5 @ 72 in.
	6 (1.8)	5 @ 96 in. or 6 @ 120 in.	5 @ 64 in. or 7 @ 120 in. ^h	5 @ 48 in. or 8 @ 96 in. ^h
	7 (2.1)	5 @ 64 in. or 7 @ 120 in. ^h	5 @ 40 in. or 8 @ 96 in. ^h	5 @ 32 in. or 8 @ 72 in.
	8 (2.4)	5 @ 48 in. or 8 @ 96 in. ^h	5 @ 32 in. or 8 @ 72 in.	5 @ 24 in. or 8 @ 56 in.
	9 (2.7)	5 @ 32 in. or 7 @ 72 in.	5 @ 24 in. or 8 @ 64 in.	6 @ 24 in. or 8 @ 48 in.
	10(3.1)	5 @ 24 in. or 8 @ 72 in.	6 @ 24 in. or 8 @ 48 in.	4 @ 8 in. or 8 @ 32 in.
12 (3.7)	4 (1.2)	No reinforcement	5 @ 120 in.	5 @ 120 in.
	5 (1.5)	5 @ 120 in.	5 @ 72 in.	5 @ 72 in.
	6 (1.8)	5 @ 72 in. or 6 @ 120 in.	5 @ 56 in. or 8 @ 120 in. ^h	5 @ 40 in. or 8 @ 96 in. ^h
	7 (2.1)	5 @ 56 in. or 8 @ 120 in. ^h	5 @ 32 in. or 8 @ 96 in. ^h	5 @ 24 in. or 8 @ 72 in.
	8 (2.4)	5 @ 40 in. or 8 @ 96 in. ^h	5 @ 24 in. or 8 @ 72 in.	6 @ 24 in. or 8 @ 48 in.
	9 (2.7)	5 @ 32 in. or 8 @ 72 in.	6 @ 24 in. or 8 @ 48 in.	4 @ 8 in. or 8 @ 40 in.
	10(3.1)	5 @ 24 in. or 8 @ 64 in.	4 @ 8 in. or 8 @ 40 in.	4 @ 8 in.
	11(3.4)	8 @ 48 in.	8 @ 32 in.	5 @ 8 in.
12(3.7)	8 @ 40 in.	5 @ 8 in.	7 @ 8 in.	

CONSTRUCTION ISSUES

This section is not a complete construction guide, but rather discusses those issues directly related to structural design assumptions. Figures 1 and 2 illustrate typical wall support conditions, drainage, and water protection.

Before backfilling, the floor diaphragm must be in place or the wall must be properly braced to resist the soil load. In addition to the absence of additional dead or live loads following construction, the assumption that there are no surcharges on the soil also means that heavy equipment should not be operated close to basement wall systems that are not designed to carry the additional load. In addition, the backfill materials should be placed and compacted in several lifts, taking care to prevent wall damage. Care should also be taken to prevent damaging the drainage, waterproofing, or exterior insulation systems, if present.

REFERENCES

1. *Building Code Requirements for Masonry Structures*, ACI 530-99/ASCE 5-99/TMS 402-99. Reported by the Masonry Standards Joint Committee, 1999.
2. *Concrete Masonry Design Tables*, TR 121. National Concrete Masonry Association, 2000.
3. *Concrete Masonry Wall Design Software*, CMS-12111. National Concrete Masonry Association, 1999.
4. *International Building Code*. International Code Council, 2000.
5. *Strength Design of Reinforced Concrete Masonry Foundation Walls*, TEK 15-2A. National Concrete Masonry Association, 1997.
6. *Standard Specification for Loadbearing Concrete Masonry Units*, ASTM C 90-01. American Society for Testing and Materials, 2001.
7. *Standard Specification for Grout Masonry*, ASTM C476-01. American Society for Testing and Materials, 2001.

Recommended protective coatings for waterproofing exterior face of walls

- 1) two 1/4 inch (6.4 mm) thick coats of portland cement, or,
- 2) one 1/4 inch (6.4 mm) thick coat of portland cement plaster plus two brush coats of bituminous waterproofing, or,
- 3) one heavy troweled-on coat of cold, fiber-reinforced asphaltic mastic.

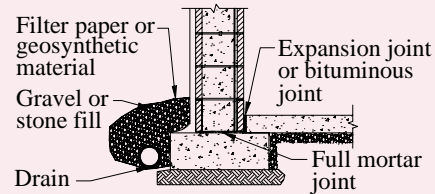

Note: wet and impermeable soils may require additional waterproofing

Figure 1—Typical Base of Foundation Wall

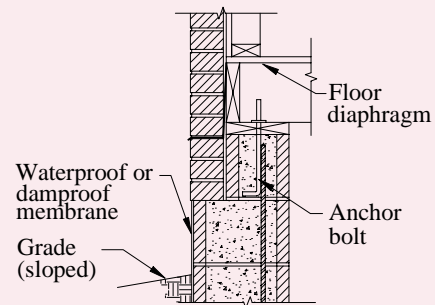

Figure 2—Typical Top of Foundation Wall

Provided by:
Cinder & Concrete Block Corporation

NCMA and the companies disseminating this technical information disclaim any and all responsibility and liability for the accuracy and the application of the information contained in this publication.

NATIONAL CONCRETE MASONRY ASSOCIATION
2302 Horse Pen Road, Herndon, Virginia 20171-3499
www.ncma.org

To order a complete TEK Manual or TEK Index,
contact NCMA Publications (703) 713-1900