

Provided by:  
Cinder & Concrete Block Corporation

NCMA TEK

National Concrete Masonry Association  
an information series from the national authority on concrete masonry technology

## EMPIRICAL DESIGN OF CONCRETE MASONRY WALLS

TEK 14-8A  
Structural (2001)

**Keywords:** allowable stress, anchorage, bonding, building codes, empirical design, height/thickness ratio, intersecting walls, lateral support, nonbearing wall, parapet, partition walls, shear wall, unreinforced concrete masonry, vertical loads, wall ties

### INTRODUCTION

Empirical design is a procedure of proportioning and sizing unreinforced masonry elements based on known historical performance for a given application. Empirical provisions preceded the development of engineered masonry design, and can be traced back several centuries. This approach to design is based on historical experience in lieu of analytical methods. It has proven to be an expedient design method for typical loadbearing structures subjected to relatively small wind loads and located in areas of low seismic risk. Empirical design has also been used extensively for the design of exterior curtain walls and interior partitions.

Using empirical design, vertical and lateral load resistance is governed by prescriptive criteria which include wall height to thickness ratios, shear wall length and spacing, minimum wall thickness, maximum building height, and other criteria, which have proven to be effective through years of experience.

This TEK is based on the provisions in Chapter 5 of *Building Code Requirements for Masonry Structures* (ref. 1). These empirical design requirements do not apply to other design methods such as allowable stress or limit states design.

### APPLICABILITY OF EMPIRICAL DESIGN

All elements of masonry structures are permitted to be designed by empirical methods when assigned to Seismic Design Category (SDC) A, B or C and where the basic wind speed (three-second gust, not fastest mile) is less than or equal to 110 mph (145 km/hr), as defined in *Minimum Design Loads for Buildings and Other Structures*, ASCE 7-98 (ref. 3). A wind speed of this velocity generally applies along the East and Gulf coasts of the United States. When empirically designed elements are part of the seismic lateral force resisting system, their use is limited to SDC A.

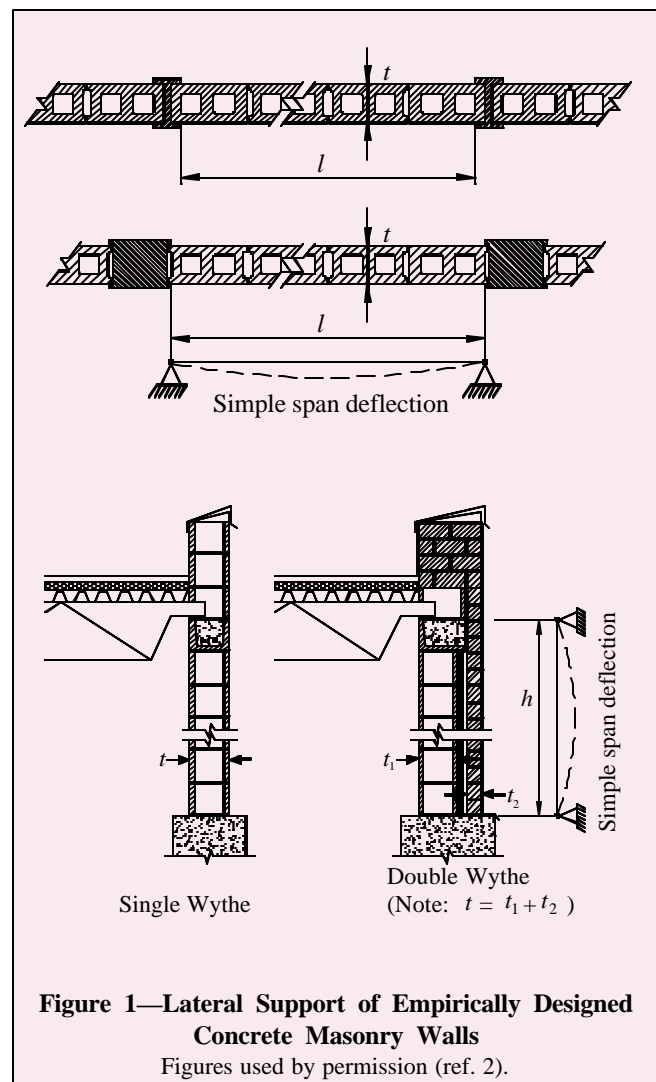



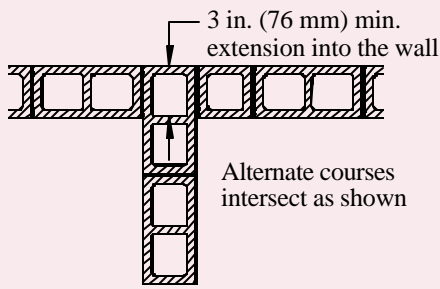

Loadbearing walls

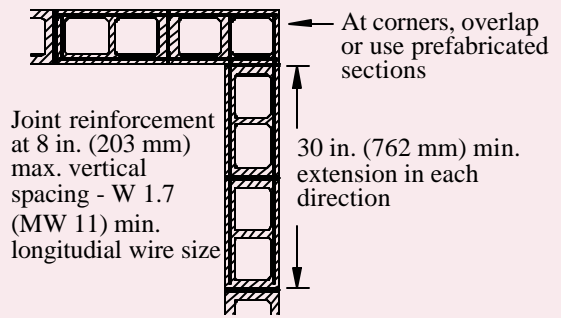

Loadbearing walls

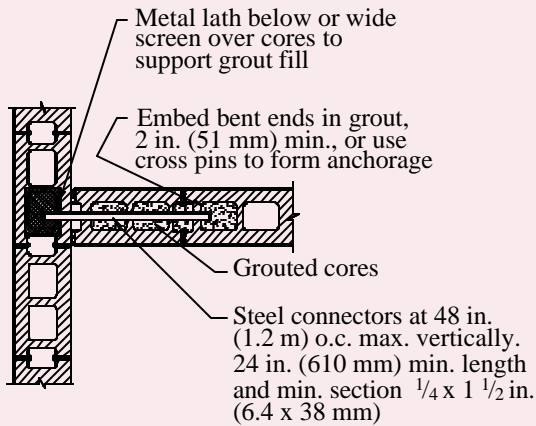

Loadbearing walls

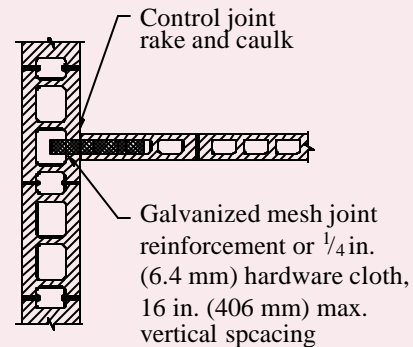

Interior nonloadbearing walls

Note: Other metal ties, joint reinforcement or anchors may be used provided they are spaced to provide an equivalent area of anchorage.

**Figure 2—Empirical Anchorage Requirements for Lateral Support of Intersecting Masonry Walls**

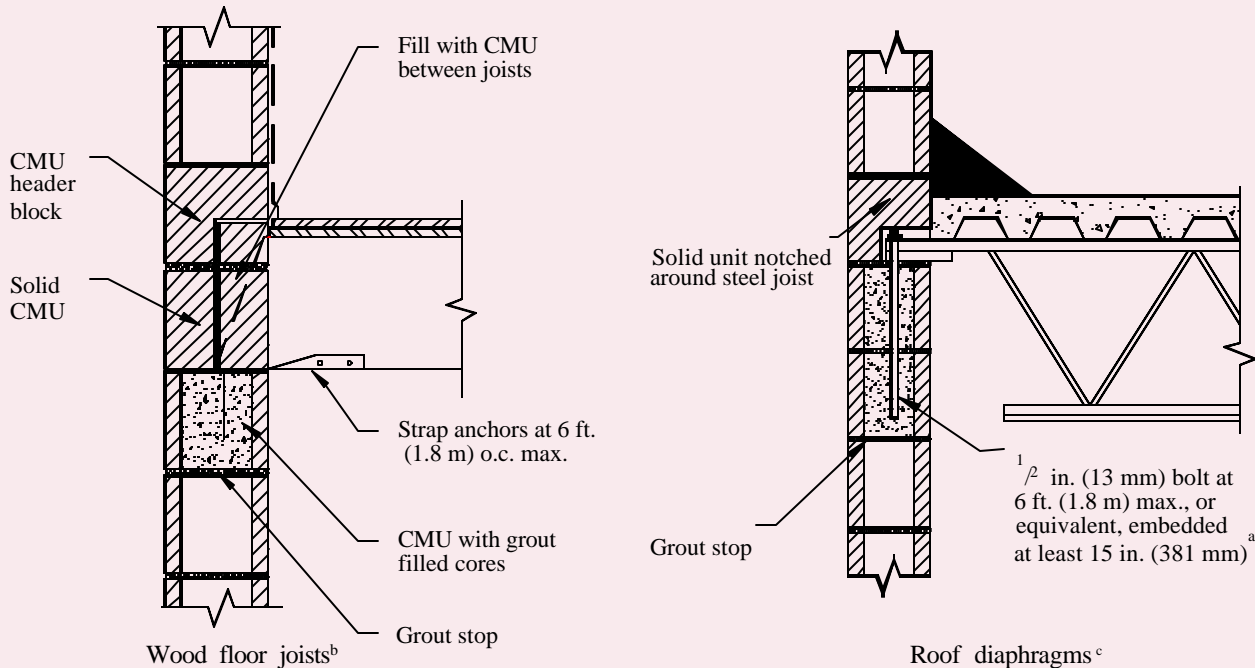

Notes:

<sup>a</sup> As an alternative, the bolts can be hooked or welded to at least 0.2 in.<sup>2</sup> (129 mm<sup>2</sup>) of bond beam reinforcement placed not less than 6 in. (152 mm) from the top of the wall.

<sup>b</sup> Wood joists anchored to parallel masonry walls require metal straps which extend over and under the joists and which are secured to at least three joists. Anchors must be spaced at a maximum of 6 ft (1.8 m). Blocking is required between joists at each strap anchor.

<sup>c</sup> Steel floor joists which bear on and are anchored to masonry walls require 3/8 in. (9.5 mm) reinforcing bars spaced a maximum of 6 ft (1.8 m) on center, or equivalent anchorage. Where joists are parallel to the wall, anchors must be located at joist cross bridging.

**Figure 3—Empirical Anchorage Requirements for Floor and Roof Diaphragms**

ments for Masonry Structures (ref. 1) contains additional guidance for concentrated loads. According to the commentary, when concentrated loads act on empirically designed masonry, the course immediately under the point of bearing should be a solid unit or be filled solid with mortar or grout. Further, when the concentrated load acts on the full wall thickness, the allowable stresses under the load may be increased by 25 percent. The allowable stresses may be increased by 50 percent when concentrated loads act on concentrically placed bearing plates that are greater than one-half but less than the full area.

### Anchorage for Lateral Support

Where empirically designed masonry walls depend on cross walls, roof diaphragms, floor diaphragms, or structural frames for lateral support, it is essential that the walls be properly anchored so that the imposed loads can be transmitted from the wall to the supporting element. Minimum anchorage requirements for inter-

secting walls and for floor and roof diaphragms are shown in Figures 2 and 3, respectively.

Masonry walls are required to be anchored to structural frames that provide lateral support by 1/2 in. (13 mm) diameter bolts spaced at a maximum of 4 ft (1.2 m), or with other bolts and spacings that provide equivalent anchorage. The bolts must be embedded a minimum of 4 in. (102 mm) into the masonry.

### Shear Walls

Where the structure depends on masonry walls for lateral stability against wind or earthquake forces, shear walls must be provided parallel to the direction of the lateral forces as well as in a perpendicular plane, for stability.

Requirements for empirically designed masonry shear walls are shown in Figure 4.

Shear wall spacing is determined empirically by the length-to-width aspect ratio of the diaphragms that transfer lateral forces to the shear walls, as listed in Table 4. In addition, roofs must be designed and constructed in a manner such that they will not impose thrust perpendicular to the shear walls to which they are attached.

The height of empirically designed shear walls is not permitted to exceed 35 ft (10.7 m). The minimum nominal thickness of shear walls is 8 in. (203 mm).

### Bonding of Multiwythe Walls

Wythes of multiwythe masonry walls are required to be bonded together. Bonding can be achieved using masonry headers, metal wall ties, or prefabricated joint reinforcement, as illustrated in Figure 5. Various empirical requirements for each of these bonding methods are given below.

**Bonding of solid unit walls with masonry headers.** Where masonry headers are used to bond wythes of solid masonry construction, at least 4 percent of the wall surface of each face must be composed of headers, which must extend at least 3 in. (76 mm) into the backing. The distance between adjacent full-length headers may not exceed 24 in. (610 mm) in either the horizontal or vertical direction. In walls where a single header does not extend through the wall, headers from opposite sides must overlap at least 3 in. (76 mm), or headers from opposite sides must be covered with another header course which overlaps the header below by at least 3 in. (76 mm).

**Bonding of hollow unit walls with masonry headers.** Where two or more hollow units are used to make up the thickness of a wall, the stretcher courses must be bonded at vertical intervals not exceeding 34 in. (864 mm) by lapping at least 3 in. (76 mm) over the unit below, or by lapping at vertical intervals not exceeding 17 in. (432 mm) with units which are at least 50 percent greater in thickness than the units below.

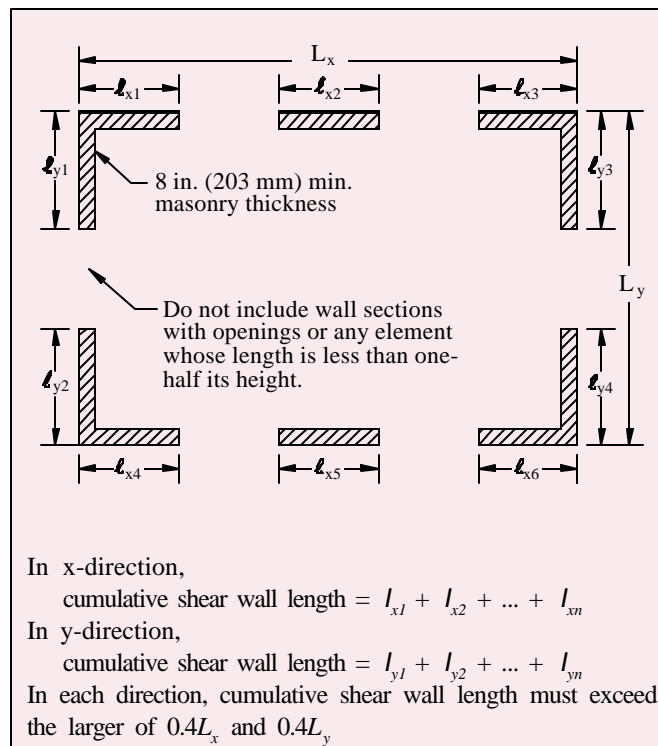

**Figure 4—Empirically Designed Shear Wall Requirements**

**Table 4—Shear Wall Diaphragm Length-to-Width Ratios (ref. 1)**

Floor or roof construction	Maximum length-to-width ratio of diaphragm panel
Cast-in-place concrete	5:1
Precast concrete	4:1
Metal deck with concrete fill	3:1
Metal deck with no fill	2:1
Wood diaphragm	2:1

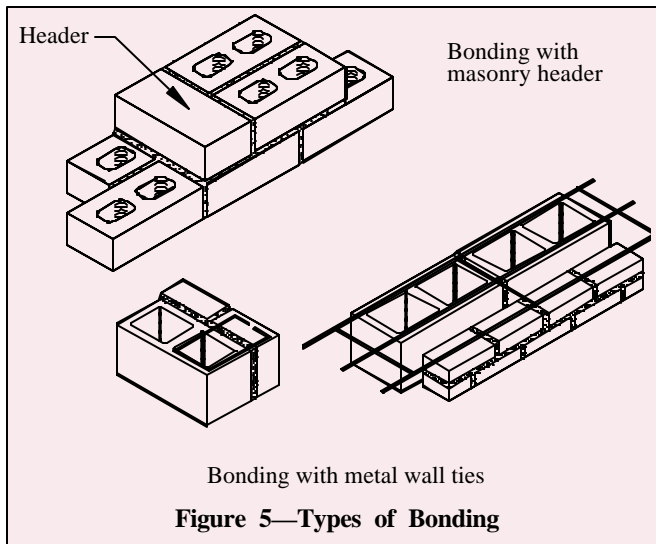

Figure 5—Types of Bonding

#### Bonding with metal wall ties.

Wire size W2.8 (MW18) wall ties, or metal wire of equivalent stiffness, may be used to bond wythes. Each  $4\frac{1}{2}$  ft<sup>2</sup> (0.42 m<sup>2</sup>) of wall surface must have at least one tie. Ties must be spaced a maximum of 24 in. (610 mm) vertically and 36 in. (914 mm) horizontally. Hollow masonry walls must use rectangular wall ties for bonding. In other walls, ends of ties must be bent to 90° angles to provide hooks no less than 2 in. (51 mm) long. Additional bonding ties are required at all openings, and must be spaced a maximum of 3 ft (914 mm) apart around the perimeter and located within 12 in. (305 mm) of the opening. Wall ties cannot include drips.

#### Bonding with prefabricated joint reinforcement.

Where adjacent wythes of masonry are bonded with prefabricated joint reinforcement, there shall be at least one cross wire serving as a tie for each  $\frac{2}{3}$  ft<sup>2</sup> (0.25 m<sup>2</sup>) of wall area. The joint reinforcement must be spaced 24 in. (610 mm) or closer vertically. Cross wires on prefabricated joint reinforcement shall not be smaller than wire size W1.7 (MW11) and shall be without drips. The longitudinal wires must be embedded in the mortar.

### Miscellaneous Empirical Requirements

#### Chases and Recesses

Masonry directly above chases or recesses wider than 12 in. (305 mm) must be supported on lintels.

#### Lintels

Lintels are designed as reinforced beams, according to Section 2.3.3.4 of *Building Code Requirements for Masonry Structures* (ref. 1). End bearing must be at least 4 in. (102 mm), although 8 in. (203 mm) is typical.

#### Support on Wood

Empirically designed masonry is not permitted to be supported by wood girders or other forms of wood construction, due to expected deformations in wood from deflection and moisture, causing distress in the

masonry, and due to potential safety implications in the event of fire.

#### Corbelling

Only solid masonry units may be used for corbelling. For solid walls, the corbelled masonry can project beyond the face of the wall up to one-half of the wall thickness, as long as the opposite side of the wall remains in its same plane. For hollow walls, the corbelled projection cannot exceed one-half the wythe thickness. The maximum projection of an individual masonry unit must be either one-half the height of the unit or one-third its thickness at right angles to the wall, whichever is less.

### EMPIRICALLY DESIGNED PARTITION WALLS

In many cases, the building structure is designed using traditional engineered methods, such as strength design or allowable stress design, but the interior non-loadbearing masonry walls are empirically designed. In these cases, the partition walls are supported according to the provisions listed in Tables 1 and 2, but it is important that the support conditions provide isolation between the partition walls and the building's structural elements to prevent the building loads from being transferred into the partition. The anchor, or other support, must provide the required lateral support for the partition wall while also allowing for differential movement. This is in contrast to the "Anchorage for Lateral Support" section, which details anchorage requirements to help ensure adequate load transfer between the building structure and the loadbearing masonry wall.

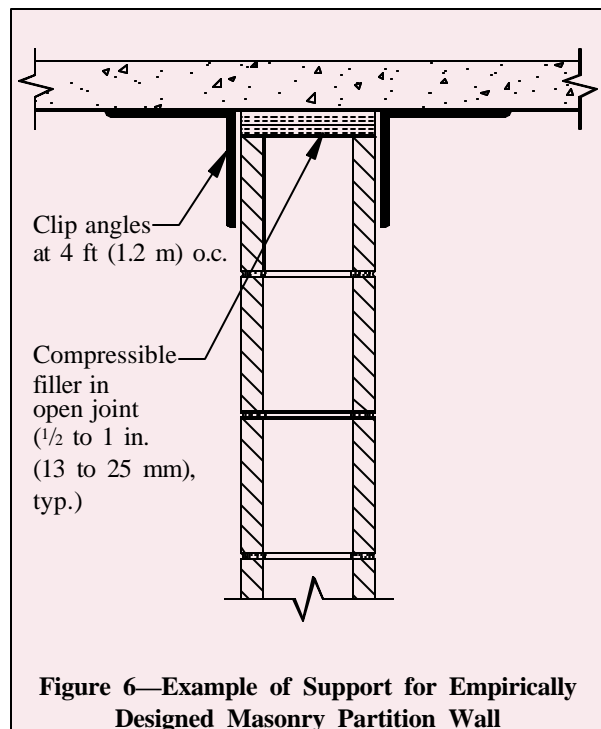

Figure 6—Example of Support for Empirically Designed Masonry Partition Wall

Figure 6 shows an example of such a support, using clip angles. C channels or adjustable anchors could be used as well. The gap at the top of the wall should be between  $\frac{1}{2}$  and 1 in. (13 and 25 mm), or as required to accommodate the anticipated deflection. The gap is filled with compressible filler, mineral wool or a fire-rated material, if required. Fire walls may also require a sealant to be applied at the bottom of the clip angles. This joint should not be filled with mortar, as it may allow load transfer between the structure and the partition wall.

## REFERENCES

1. *Building Code Requirements for Masonry Structures*, ACI 530/ASCE 5/TMS 402. Reported by the Masonry Standards Joint Committee, 2002.
2. *Masonry Designer's Guide*. American Concrete Institute, Council for Masonry Research, and The Masonry Society, 1999.
3. *Minimum Design Loads for Buildings and Other Structures*, ASCE 7-98. New York, NY: American Society of Civil Engineers, 1998.

Provided by:  
Cinder & Concrete Block Corporation

NCMA and the companies disseminating this technical information disclaim any and all responsibility and liability for the accuracy and the application of the information contained in this publication.