

*2-12. Classify each of the structures as statically determinate, statically indeterminate, or unstable. If indeterminate, specify the degree of indeterminacy.

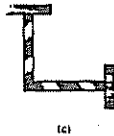

a)
 $r > 3n$
 $4 > 3(1)$
 Statically indeterminate to 1°.

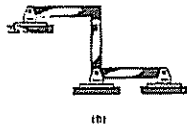
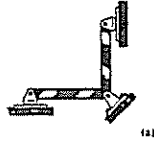
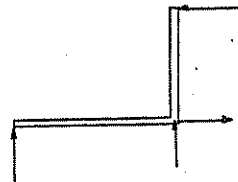

Ans

b)
 Parallel reactions
 Unstable.

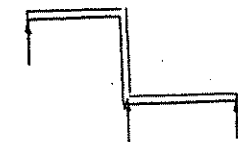

Ans

c)
 $r > 3n$
 $6 > 3(1)$
 Statically indeterminate to 3°.

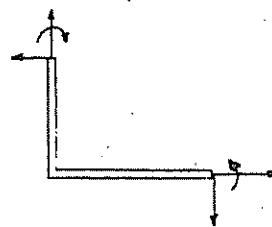

Ans

d)
 Parallel reactions
 Unstable.



Ans

2-23. Determine the vertical reactions at the supports *A* and *B*. Assume *A* is a roller and *B* is a pin.

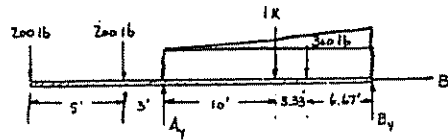
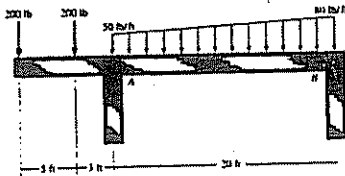

Resultant forces : 1) $(50)(20) = 1000$ lb acts 10 ft from right

2) $\frac{1}{2}(30)(20) = 300$ lb acts 6.67 ft from right

$$\begin{aligned} \curvearrowright + \Sigma M_B = 0: & \quad 300(6.67) + 1000(10) + 200(23) + 200(28) - A_y(20) = 0 \\ & \quad A_y = 1110.05 \text{ lb} = 1.11 \text{ k} \quad \text{Ans} \\ \rightarrow \Sigma F_x = 0: & \quad B_x = 0 \quad \text{Ans} \\ + \downarrow \Sigma F_y = 0: & \quad 200 + 200 + 1000 + 300 - 1110.05 - B_y = 0 \\ & \quad B_y = 589.95 \text{ lb} = 590 \text{ lb} \quad \text{Ans} \end{aligned}$$

*2-24. Determine the reactions on the beam.

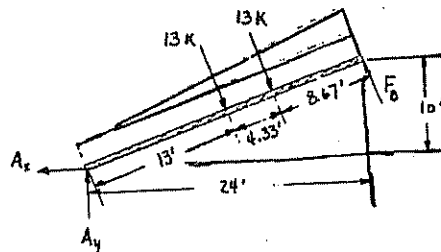

$$\begin{aligned} \curvearrowright + \Sigma M_A = 0: & \quad F_B(26) - 13(13) - 13(17.33) = 0 \\ & \quad F_B = 15.17 \text{ k} = 15.2 \text{ k} \quad \text{Ans} \\ \rightarrow \Sigma F_x = 0: & \quad -A_x + 26\left(\frac{10}{26}\right) - 15.17\left(\frac{10}{26}\right) = 0 \\ & \quad A_x = 4.17 \text{ k} \quad \text{Ans} \\ + \uparrow \Sigma F_y = 0: & \quad A_y - 26\left(\frac{24}{26}\right) + 15.17\left(\frac{24}{26}\right) = 0 \\ & \quad A_y = 10.0 \text{ k} \quad \text{Ans} \end{aligned}$$

*3-4. A sign is subjected to a wind loading that exerts horizontal forces of 300 lb on joints B and C of one of the side supporting trusses. Determine the force in each member of the truss and state if the members are in tension or compression.

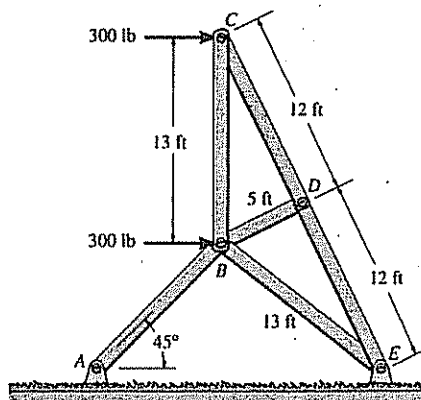

Joint C:

$$\rightarrow \Sigma F_x = 0; \quad 300 - F_{CD} \sin 22.62^\circ = 0$$

$$F_{CD} = 780 \text{ lb (C)} \quad \text{Ans}$$

$$+\uparrow \Sigma F_y = 0; \quad -F_{CB} + 780 \cos 22.62^\circ = 0$$

$$F_{CB} = 720 \text{ lb (T)} \quad \text{Ans}$$

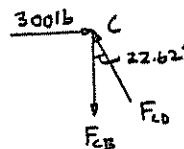

Joint D:

$$+\rightarrow \Sigma F_x = 0; \quad F_{DB} = 0 \quad \text{Ans}$$

$$+\nearrow \Sigma F_y = 0; \quad 780 - F_{DE} = 0$$

$$F_{DE} = 780 \text{ lb (C)} \quad \text{Ans}$$

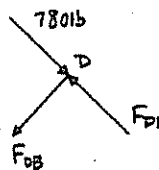

Joint B:

$$\rightarrow \Sigma F_x = 0; \quad 300 - F_{BA} \cos 45^\circ + F_{BE} \sin 45.24^\circ = 0$$

$$+\uparrow \Sigma F_y = 0; \quad 720 - F_{BA} \sin 45^\circ - F_{BE} \cos 45.24^\circ = 0$$

$$F_{BE} = 297 \text{ lb (T)} \quad \text{Ans}$$

$$F_{BA} = 722 \text{ lb (T)} \quad \text{Ans}$$

