

14-1. Determine the stiffness matrix K for the assembly. Take $A = 0.5 \text{ in}^2$ and $E = 29(10^3) \text{ ksi}$ for each member.

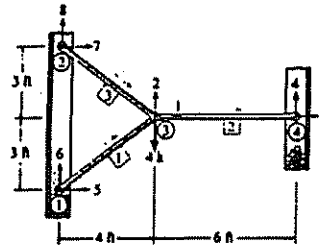

Member 1: $\lambda_x = \frac{4-0}{5} = 0.8$; $\lambda_y = \frac{3-0}{5} = 0.6$

$$k_1 = \frac{AE}{60} \begin{bmatrix} 0.64 & 0.48 & -0.64 & -0.48 \\ 0.48 & 0.36 & -0.48 & -0.36 \\ -0.64 & -0.48 & 0.64 & 0.48 \\ -0.48 & -0.36 & 0.48 & 0.36 \end{bmatrix}$$

Member 2: $\lambda_x = \frac{10-4}{6} = 1$; $\lambda_y = \frac{3-3}{6} = 0$

$$k_2 = \frac{AE}{72} \begin{bmatrix} 1 & 0 & -1 & 0 \\ 0 & 0 & 0 & 0 \\ -1 & 0 & 1 & 0 \\ 0 & 0 & 0 & 0 \end{bmatrix}$$

Member 3: $\lambda_x = \frac{4-0}{5} = 0.8$; $\lambda_y = \frac{3-6}{5} = -0.6$

$$k_3 = \frac{AE}{60} \begin{bmatrix} 0.64 & -0.48 & -0.64 & 0.48 \\ -0.48 & 0.36 & 0.48 & -0.36 \\ -0.64 & 0.48 & 0.64 & -0.48 \\ 0.48 & -0.36 & -0.48 & 0.36 \end{bmatrix}$$

Assembly stiffness matrix: $K = k_1 + k_2 + k_3$

$$K = \begin{bmatrix} 510.72 & 0 & -201.39 & 0 & -154.67 & -116 & -154.67 & 116 \\ 0 & 174 & 0 & 0 & -116 & -87.0 & 116 & -87.0 \\ -201.39 & 0 & 201.39 & 0 & 0 & 0 & 0 & 0 \\ 0 & 0 & 0 & 0 & 0 & 0 & 0 & 0 \\ -154.67 & -116 & 0 & 0 & 154.67 & 116 & 0 & 0 \\ -116 & -87.0 & 0 & 0 & 116 & 87.0 & 0 & 0 \\ -154.67 & 116 & 0 & 0 & 0 & 0 & 154.67 & -116 \\ 116 & -87.0 & 0 & 0 & 0 & 0 & -116 & 87.0 \end{bmatrix} \text{ lbs}$$

14.2. Determine the horizontal and vertical displacements at joint ③ of the assembly in Prob. 14-1.

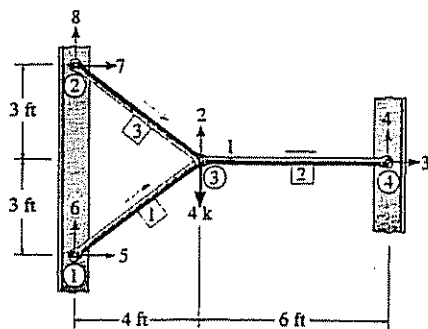

$$D_1 = \begin{bmatrix} 0 \\ 0 \\ 0 \\ 0 \\ 0 \\ 0 \end{bmatrix} \quad Q_2 = \begin{bmatrix} 0 \\ -4 \end{bmatrix}$$

Use the assembly stiffness matrix of Prob. 13-1 and applying $Q = KD$

$$\begin{bmatrix} 0 \\ -4 \\ Q_3 \\ Q_4 \\ Q_5 \\ Q_6 \\ Q_7 \\ Q_8 \end{bmatrix} = \begin{bmatrix} 510.72 & 0 & -201.39 & 0 & -154.67 & -116 & -154.67 & 116 \\ 0 & 174 & 0 & 0 & -116 & -87.0 & 116 & -87.0 \\ -201.39 & 0 & 201.39 & 0 & 0 & 0 & 0 & 0 \\ 0 & 0 & 0 & 0 & 0 & 0 & 0 & 0 \\ -154.67 & -116 & 0 & 0 & 154.67 & 116 & 0 & 0 \\ -116 & -87.0 & 0 & 0 & 116 & 87.0 & 0 & 0 \\ -154.67 & 116 & 0 & 0 & 0 & 0 & 154.67 & -116 \\ 116 & -87.0 & 0 & 0 & 0 & 0 & -116 & 87.0 \end{bmatrix} \begin{bmatrix} D_1 \\ D_2 \\ D_3 \\ D_4 \\ D_5 \\ D_6 \\ D_7 \\ D_8 \end{bmatrix}$$

Partition matrix

$$0 = 510.72(D_1) + 0(D_2)$$

$$-4 = 0(D_1) + 174(D_2)$$

Solving

$$D_1 = 0$$

$$D_2 = -0.02299 \text{ in.}$$

Thus,

$$D_1 = 0$$

Ans

$$D_2 = -0.0230 \text{ in.}$$

Ans