

CIEG 212: Solid Mechanics

Solution

Quiz #1
March 6, 2008
Closed Book; Closed Notes
Duration: 20 minutes

Problem 1 (30 points)

Consider the beam shown below. The beam is loaded by applied concentrated forces and a concentrated moment of couple, as well as by a uniformly distributed load over a portion of the beam.

Determine the reactions at the supports (support *A* is a frictionless pin; that at *B* is a roller). Make sure to show a complete and correct free-body diagram.

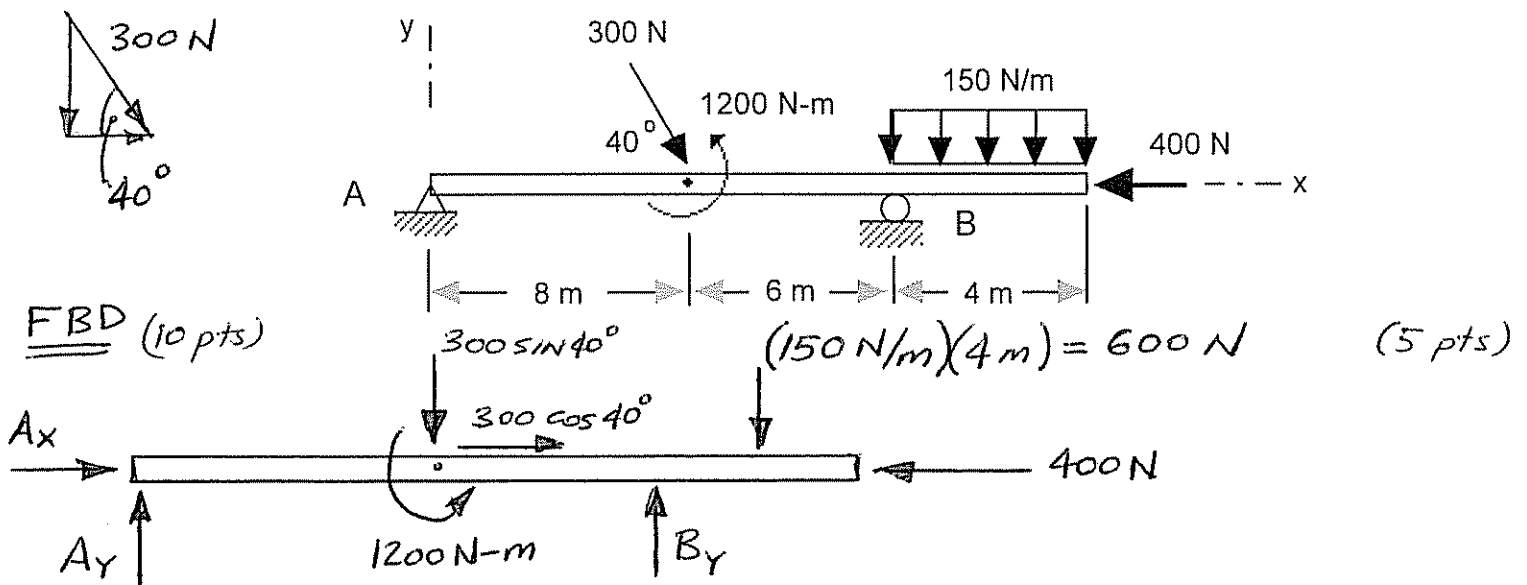

(5 pts) $\sum F_x = A_x + 300 \cos 40^\circ - 400 = 0 \Rightarrow A_x = 170.2 \text{ N} (\rightarrow)$

(5 pts) $\sum M_A = 1200 \text{ N-m} - (300 \sin 40^\circ)(8 \text{ m}) + 14 B_y - (600 \text{ N})(16 \text{ m}) = 0$
 $B_y = 710.2 \text{ N} (\uparrow)$

(5 pts) $\sum F_y = A_y - 300 \sin 40^\circ + B_y - 600 \text{ N} = 0$
 $A_y = 82.64 \text{ N} (\uparrow)$

Problem 2 (20 points)

Consider the beam shown below.

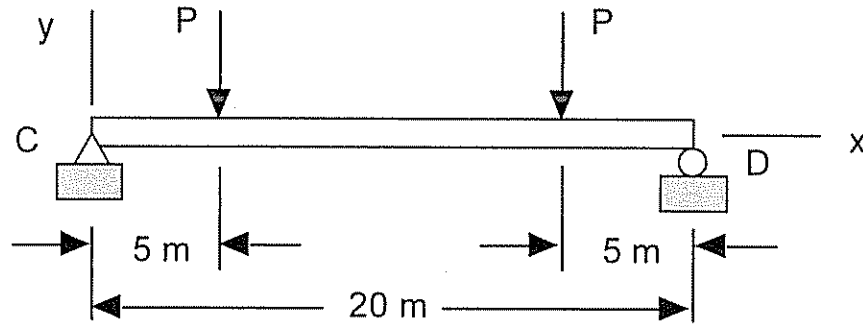

Assuming $P = 50 \text{ kN}$, determine the internal forces and bending moment at

- a) $x = 3.0 \text{ m}$
- b) $x = 10.0 \text{ m}$

In carrying out your work, please show a complete and correct free-body diagram.

To simplify your work note that the vertical reactions at C and D are each equal to P and that the horizontal reaction at C is equal to zero. There is no need to re-compute these reactions!

* at $x = 3.0 \text{ m}$
(10 pts)

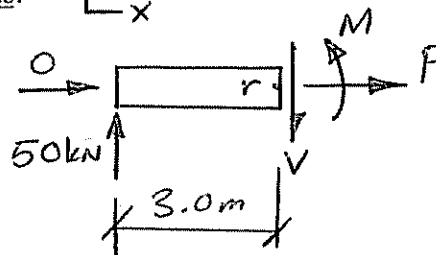

$$\sum F_x = P = 0$$

$$\sum F_y = 50 \text{ kN} - V = 0 \Rightarrow V = 50.0 \text{ kN} (\downarrow)$$

$$\sum M_r = M - (50 \text{ kN})(3.0 \text{ m}) = 0$$

$$M = 150.0 \text{ kN-m}$$

* at $x = 10.0 \text{ m}$

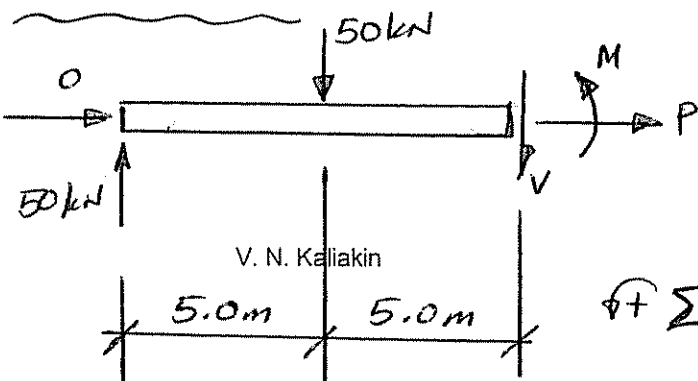

$$\sum F_x = P = 0$$

$$\sum F_y = 50 - 50 - V = 0 \Rightarrow V = 0$$

$$\sum M_r = M + (50 \text{ kN})(5 \text{ m}) - (50 \text{ kN})(10 \text{ m}) = 0$$

$$M = 250.0 \text{ kN-m} \quad (10 \text{ pts})$$